

DETROIT DIESEL

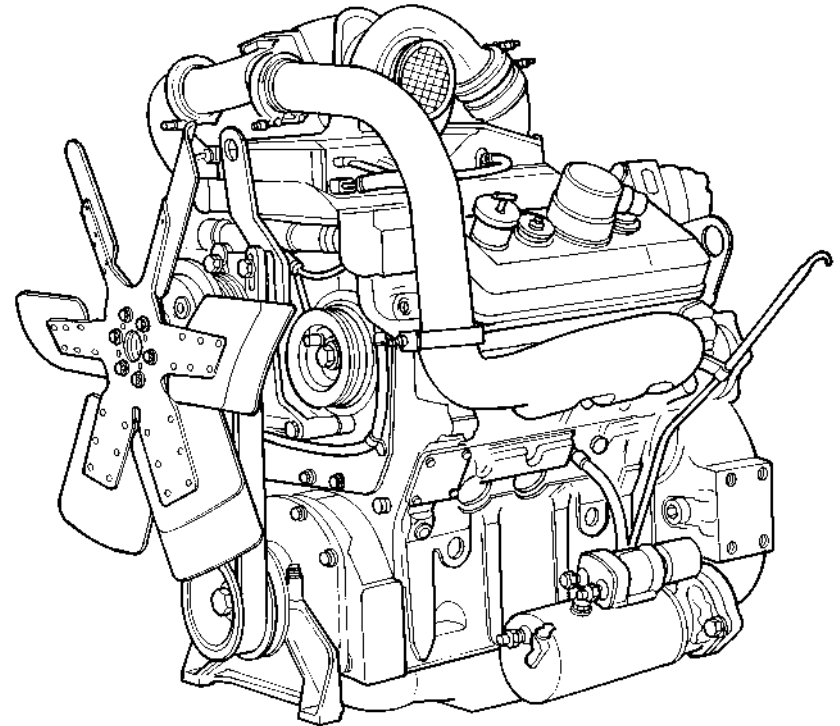

Series 92



DETROIT DIESEL
CORPORATION



13400 Outer Drive, West / Detroit, Michigan 48239-4001
Telephone: 313-592-5000
Telex: 4320091 / TWX: 810-221-1649
FAX: 313-592-7288

Engine Operator's Guide

To the Operator

This guide contains instructions on the safe operation and preventive maintenance of your Detroit Diesel engine. Maintenance instructions cover routine engine services such as lube oil and filter changes in enough detail to permit self-servicing, if desired.

The operator should become familiar with the contents of this manual before operating the engine or carrying out maintenance procedures.

Power-driven equipment is only as safe as the person operating the controls. You are urged, as the operator of this diesel engine, to keep fingers and clothing away from the revolving belts, drive shafts, etc. on the engine installation.

Throughout this guide **CAUTIONS** regarding personal safety and **NOTICES** regarding engine perfor-

mance or service life will appear. To avoid personal injury and ensure long engine service life, always heed these instructions.

Whenever possible, it will benefit you to rely on an authorized Detroit Diesel service outlet for all your service needs from maintenance to major parts replacement. Authorized service outlets worldwide stock factory original parts and have the specialized equipment and experienced, trained personnel to provide prompt preventive maintenance and skilled engine repairs.

The information and specifications in this publication are based on the information in effect at the time of approval for printing. Contact an authorized Detroit Diesel service outlet for information on the latest revision. The right is reserved to make changes at any time without obligation.

Information in this guide is for diesel-fueled Series 92 engines. For alcohol-fueled engines refer to publication "Alcohol-Fueled Series 92 Engines" (Form 6SE508), available from authorized Detroit Diesel distributors.

WARRANTY

The applicable engine warranty is contained in the booklet entitled "Warranty Information for Series 53, 71 and 92 Engines," available from authorized Detroit Diesel service outlets.

Keep this Operators Guide with the engine installation at all times. It contains important operating, maintenance, and safety instructions.

Table of Contents

Subject	Page
Engine Model and Serial Number Designation.....	1
DDEC II/DDEC III Engine Identification	1
Option and Certification Labels	1
OPERATING INSTRUCTIONS	3
Preparations for Starting the Engine the First Time	3
Starting the Engine.....	6
Running the Engine.....	8
Stopping the Engine	10
Emergency Jump Starting	11
DDEC OPTIONS	12
Vehicle, Industrial Engines.....	12
Marine Engines	20
ENGINE SYSTEMS	24
Fuel System.....	24
Lubrication System	24
Air System	24
Cooling System	24
Electrical System.....	24
Exhaust System.....	24
ENGINE MAINTENANCE SCHEDULES	26-31
LUBRICATION AND PREVENTIVE MAINTENANCE INTERVALS	32-44
"HOW TO" SECTION	45-60
How to Select Lubricating Oil	45
When to Change Oil.....	47
How to Replace the Lube Oil Filter	48
How to Select Fuel Oil.....	50
How to Replace the Fuel Filter and Strainer	53
Engine Out of Fuel—How to Restart	54
How to Select Coolant.....	55
How to Drain and Flush the Cooling System	59
When to Service the Dry Type Air Cleaner	60
BASIC TROUBLESHOOTING	61-64
ENGINE STORAGE	65-69
SERVICE PUBLICATIONS	70
CUSTOMER ASSISTANCE	71-72
SPECIFICATIONS	73-74

ENGINE MODEL AND SERIAL NUMBER DESIGNATION

The engine serial number and model number are stamped on the cylinder block in the following location (as viewed from the front):

- 6V, 8V-92 Machined pad on the left side, upper front corner just below the fire deck.
- 12V, 16V-92 Left side of the rear block, below and between the back airbox covers.

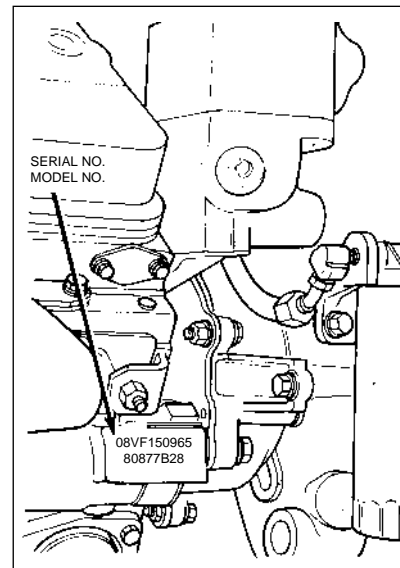

Location of Engine Serial and Model Number (8V-92 Shown)

DDEC II/DDEC III Engine Identification

Detroit Diesel Electronic Control (DDEC) systems are available as standard or optional items on many Series 92 engine models. Engines equipped with DDEC II systems are identified by the letter "B" in the sixth position of the model number. *Example: 80877B28.* Engines equipped with DDEC III systems have the letter "K" in the sixth position. *Example: 80877K28.*

Option Labels

Computerized engine option labels are attached to the valve rocker cover. These labels contain the engine serial number and model number and, in addition, list any optional equipment used on the engine. Labels also include required tune-up information (injection timing, valve lash, max. no-load RPM, etc.).

With any order for parts, the engine model and serial number must be given. If a type number is shown on the option label covering the equipment required, this number should also be included on the parts order.

Marine gears, transmissions and power take-offs generally carry their own name plates. The model and serial number information on these plates is useful when ordering parts for these assemblies.

Certification Label

If required, a certification label is attached to the valve rocker cover. This label certifies that the engine conforms to federal and certain state emissions regulations for its particular application. It also gives the operating conditions under which certification was made.

0483 CYL BLOCK
0137 CYL HEAD
0721 F/W HOUSING
0848 FLYWHEEL
0810 OIL PAN
0028 OIL PRESS REG
1230 OIL COOLER
0591 OIL FILTER
0048 BAL WT COVER
UNIT 08VF161310 S.O.

0161 AIR BOX DRAIN
0247 ENG LIFT BRKT
0177 VIB DAMPER
0431 CONN ROD/PSTN
0200 OIL PUMP
0203 OIL DIST
1031 DIPSTICK
0748 VENT SYSTEM
1689 FAN
4A42112 MODEL 80877K45

THIS ENGINE WAS
TESTED AT 0450 HP
AT 02100 RPM
INJ. TIMING 1.520
VALVE LASH .016
STARTING AID .000
THRTDLY/FMOD .000
MAX RPM NL 02225
STDGT DDEC CAM
SPEC P0677700



0396 C/S PULLEY
0458 WAT BYPASS
0177 FUEL PUMP
1303 TURBOCHARGER
1995 FUEL LINES
0648 ENGINE MOUNTS
0384 VALVE MECH
0133 OIL FIL CAP
0143 ACC DRIVE
UNIT 08VF161310 S.O.

0080 C/S PUL BELT
0426 THERMOSTAT
0324 INJECTOR
0068 FUEL MAN CONN
0747 AIR INLT HSG
NONE AIR COMP
JAKE SEE VALV MECH
0727 VENT SYSTEM
0223 ACC DRIVE
4A42112 MODEL 80877K45

0272 WATER PUMP
0462 EXH MANIFOLD
0691 BLOWER
0862 FUEL FILTER
0341 INJ CONT ELEC
0901 CAM/GR TRAIN
0425 ROCKER COVER
0761 VENT SYSTEM
0230 ACC DRIVE
SPEC P0677700



1994
FED

IMPORTANT ENGINE INFORMATION
THIS ENGINE CONFORMS TO U.S. EPA
REGULATIONS APPLICABLE TO 1994 MODEL YEAR NEW HEAVY DUTY
DIESEL ENGINES. THIS ENGINE HAS A PRIMARY INTENDED
SERVICE APPLICATION AS A HEAVY HEAVY DUTY ENGINE.

FUEL RATE AT ADV. HP 104.7 MM3/STROKE ADV. HP 500 AT 2100 RPM
INITIAL INJECTION TIMING 13 DEG. BTC CID 736
ENGINE FAMILY RDD736EJ4AR4 MIN. IDLE 600 RPM FEL BSP 0.32
MODEL 8V 92TA DDEC MFG. DATE
UNIT 08VF161310



THIS ENGINE IS NOT CERTIFIED FOR USE IN AN URBAN BUS AS DEFINED AT 40 CFR
86.093 2. SALE OF THIS ENGINE FOR USE IN AN URBAN BUS IS A VIOLATION OF
FEDERAL LAW UNDER THE CLEAN AIR ACT.

THIS ENGINE IS CERTIFIED TO OPERATE ON
LOW SULFUR DIESEL FUEL.

UNIT 08VF161310



OPERATING INSTRUCTIONS

Preparations for Starting the Engine the First Time

When preparing to start a new or newly overhauled engine or an engine which has been in storage, perform all of the operations listed below. Failure to follow these instructions may result in serious engine damage. Before a routine start, see "Daily" checks in the Engine Maintenance schedules (pages 26-31).



CAUTION:

When working near the engine, always remove loose items of clothing or jewelry that could get caught in a moving part of the engine and cause personal injury. Also wear safety glasses and hearing protection.

Cooling System Checks

1. Make sure all the drain cocks in the cooling system are installed (drain cocks are often removed for shipping) and are closed tightly.
2. Open the petcock near the top of the water-cooled turbocharger (if used), and any other petcocks, if so equipped.
3. Remove the radiator or heat exchanger pressure control cap and fill with genuine Detroit Diesel **Power Cool** antifreeze or an equivalent ethylene glycol-base antifreeze solution in the required concentration. In extremely hot environments, clean, soft, **properly inhibited** water may be used in the summer. Keep the coolant level at the bottom of the filler

neck to allow for expansion of the coolant. For more detailed coolant recommendations, refer to **How to Select Coolant** (page 55).

4. After filling the cooling system, close all petcocks. Fill the coolant recovery bottle to the "Full Cold" level, if equipped.
5. Entrapped air must be purged after filling the cooling system. To do this refer to "Inspection-Cooling System" under "Running the Engine" (page 8).
6. On industrial and off-highway units, check to make sure the front of the radiator is unblocked and free of debris.
7. On marine units, perform these additional steps:
 - Check sea water strainers and remove any accumulations of seaweed or debris. Strainers act as filters between the intake through-hull fittings and the raw water pump(s) and are easily fouled. Make sure all thru-hull valves, other valves in the cooling system, and raw water sea lines are open.
 - Remove the cover from the raw water pump. Visually inspect the impeller for signs of damaged or broken vanes. Replace the impeller if damaged. Reinstall the cover with a new gasket.

NOTICE:

Failure to install a new gasket and tighten cover bolts securely can result in pump leakage at start-up.

- Before starting the engine, prime the raw water pump by removing the pipe plug or zinc provided in the pump outlet elbow and pouring at least a pint of water into the pump. Reinstall the plug or zinc.

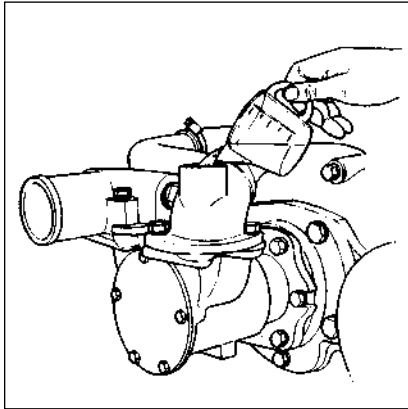

Prime the Raw Water Pump (Marine Engines)

NOTICE:

Failure to prime the raw water pump may result in damage to the pump impeller and engine overheating.

Lubricating System Checks

The lubricating oil film on the rotating parts and bearings of a new or newly overhauled engine, or one which has been in storage for six months or more, may be insufficient when the engine is started for the first time. Insufficient lubrication at start-up can cause serious damage to engine components.

To ensure an immediate flow of oil to all bearing surfaces at initial engine start-up, the engine lubrication system should be charged with a commercially available pressure pre-lubricator. After pre-lubricating, add additional oil to bring the level to the proper mark on the dipstick. Refer to **How to Select Lubricating Oil** (page 45) for lubricant requirements.

Extended Storage—An engine in storage for an extended period of

time (over winter, for example) may accumulate water in the oil pan through normal condensation of moisture (always present in the air) on the cold internal surfaces of the engine. Lube oil diluted by water cannot provide adequate bearing protection at engine startup. For this reason, Detroit Diesel recommends replacing the engine lube oil and filter(s) after extended storage.

NOTICE:

Failure to eliminate water-diluted lube oil may lead to serious engine damage at startup.

Transmission, Marine Gear—Make sure the transmission or marine gear is filled to the proper level with the fluid recommended by the gear manufacturer.

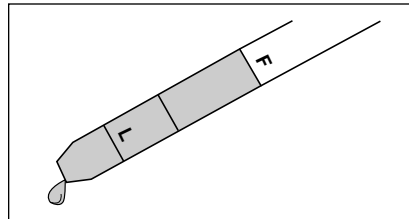

Check Lube Oil Level Before Starting

Fuel System Checks

Fill the tank with the recommended fuel. Keeping tanks full reduces water condensation and helps keep fuel cool, which is important to engine performance. Full tanks also reduce the chances for microbe (black slime) growth. Refer to **How to Select Fuel Oil** (page 50) for fuel recommendation. Make sure the fuel supply shutoff valve (if used) is open.

To ensure prompt starting and even running, the fuel system **must** be primed if air has entered the fuel system. Priming is done by connecting a manual or electric priming pump to the inlet of the secondary fuel filter. Authorized Detroit Diesel service outlets are properly equipped to perform this service.

Priming is not normally necessary if the filter elements are filled with fuel when installed and the fuel manifolds in the cylinder heads are not drained of fuel.

If the engine is equipped with a fuel/water separator, drain off any water that has accumulated. Water in fuel can seriously affect engine performance and may cause engine damage. Detroit Diesel recommends installation of a fuel/water separator wherever water contamination is a concern.

NOTICE:

Prolonged use of the starting motor and engine fuel pump to prime the fuel system can result in damage to the starter, fuel pump, and injectors, and cause erratic engine operation due to the amount of air in the lines and filters from the supply tank to the cylinder head.

Engines equipped with starting devices dependent on compressed air or gas reservoirs should always be primed before initial startup. Otherwise, reserve pressure can be exhausted and injectors may be damaged from lack of lubrication and cooling.

Under no circumstances should a starting aid such as ether be used to run the engine until the fuel system is primed. Injector damage will occur if this method is used. The heat generated by the external fuel source will cause the injector tips to be damaged when the fuel cools them. Plunger and bushing assemblies can be scored from running without lubrication.

Other Checks

Check drive belts to make sure they are in good condition (not cracked, torn, worn, or glazed) and are properly adjusted.

Make sure cable connections to the storage batteries are clean and tight. Check the hydrometer “eye” of maintenance-free batteries for charge. If lead-acid or low maintenance batteries are used, make sure battery electrolyte level is normal.

Check turbocharger for signs of oil or exhaust leaks. Leaks should be corrected before starting the engine. Check engine mounting bolts for tightness. Retighten, if necessary.

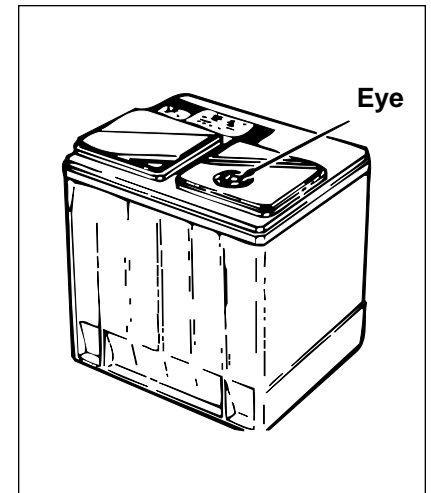

Check “Eye” of Maintenance-Free Batteries

Starting the Engine

Before starting the engine the first time, perform the operations listed under **Preparations for Starting the Engine the First Time** (pages 3-5).

If the engine has an emergency manual or automatic shutdown system, make sure the control is set in the *open* position before starting. The turbocharger may be seriously damaged if the engine is cranked with the air shutdown in the *closed* position. On engines with dual air shutdown, both air shutoff valves must be in the open position before starting the engine.

NOTICE:

The blower will be seriously damaged if operated with the air shutoff valve in the *closed* position.

If the unit is located in a closed room, start the room ventilating fan or open the windows, as weather conditions permit, so ample air is available for the engine.

The engine may require the use of a cold weather starting aid if the ambient temperature is below 40°F (4°C).



CAUTION:

Starting fluid used in capsules is highly flammable, toxic, and possesses sleep-inducing properties.

Initial Engine Start Non-DDEC Engine

1. Position the transmission or marine gear in park or neutral.
2. Set the speed control lever at part throttle, then bring it back to the desired no-load speed. In addition, make sure the stop lever on

the cover of mechanical governors is in the run position.

3. Press the starter switch firmly.

NOTICE:

To prevent serious starting motor damage, do not press the starter switch again after the engine has started.

Air Starter—Because of the limited volume of most storage tanks and the relatively short duration of the cranking cycle, it is important to **make sure the engine is ready to start before activating the air starter**. Start an engine equipped with an air starter as follows:

1. Check the pressure in the air storage tank. (Most air starter-equipped installations have a dash-mounted pressure gauge.) If necessary, add air to bring the pressure up to at least the recommended minimum for starting.
2. Press the starter button firmly and hold until the engine starts.

Starting Tip—Non-DDEC Electric Start Engine:

Some white smoke is normal at start-up when the engine is cold and will clear up shortly after the engine warms. However, if you experience excessive smoke at cold start-up, depress the stop button or cable at the same time you press the starter button and crank the engine for a few seconds. Release the stop button or cable and continue to crank the engine until it starts (but not longer than 15 seconds). This will preheat the cylinders and reduce white smoke at start-up.

Initial Engine Start—DDEC Vehicle, Industrial Engine

1. With the transmission in neutral or park, turn the ignition key on.

You will notice that both the "Check Engine" and "Stop Engine" lights will come on. This is the result of the DDEC computer diagnosing the system to ensure everything is functional, including the light bulbs for the "Check Engine" and "Stop Engine" warning lights. If everything is okay, both lights will go out in approximately five seconds.

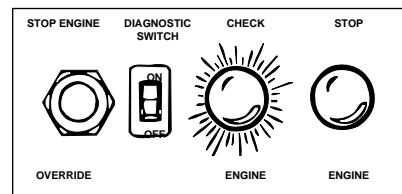

Typical Shutdown Override Switch and Engine Lights

2. With foot **OFF** the foot pedal, start the engine **after** the lights go out. Start the engine by pressing the starter switch firmly.

NOTICE:

If the warning lights stay on, or if they do not come on momentarily after starting the engine, consult with a DDEC technician. Operating the engine under these circumstances may result in engine damage.

NOTICE:

To prevent serious starting motor damage, do not press the starter switch again after the engine has started.

If the engine fails to start within 15 seconds, release the starter switch and allow the starting motor to cool for 15 seconds before trying again. If the engine fails to start after four attempts, an inspection should be made to determine the cause.

Initial Engine Start— DDEC Marine Engine

1. With the marine gear in neutral, turn the ignition key on. You will notice that both the "Check Engine" and "Stop Engine" lights on the Boat Builder Interface Module (BBIM) will come on. This is the result of the DDEC computer diagnosing the system to ensure everything is functional, including the light bulbs for the "Check Engine" and "Stop Engine" warning lights. If everything is okay, both lights will go out in approximately five seconds.

The electronic display panels at the control bridge also complete a diagnostic check when the ignition key is turned on.

The electronic display module or "EDM" (if used) does not contain "Check Engine" and "Stop Engine" lamps, but features the words "STOP" and "CHECK" on the panel face. When the ignition key is turned on, the EDM checks every segment on the panel face and sets itself for display of engine parameters.

If the vessel is equipped with the DDEC Imaging System, you will notice that it also does not contain "Check Engine" and "Stop Engine" lamps, but does a self-diagnostic check when turned on.

Should a system fault be present at any time, both display versions will present on the screen the diagnostic code number and a brief word description of the fault condition.

2. Start the engine after the lights go out. Start the engine by pressing the starter switch firmly.

NOTICE:

If the warning lights on the BBIM stay on, or if they do not come on momentarily after turning on the ignition key, consult with a DDEC service technician. In the former case the bridge displays will show the active fault codes. Operating the engine under these circumstances may result in engine damage.

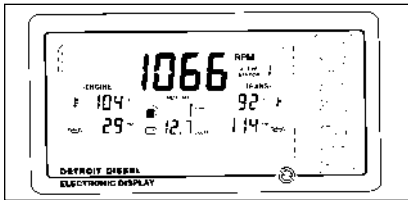

Electronic Display Module

If the engine fails to start within 15 seconds, release the starter switch and allow the starting motor to cool for 15 seconds before trying again. If the engine fails to start after four attempts, an inspection should be made to determine the cause.



DDEC Imaging System

NOTICE:

To prevent starting motor damage, do not press the starter switch again after the engine has started.

Running the Engine

Oil Pressure

Observe the oil pressure gauge or electronic display immediately after starting the engine. A good indicator that all of the moving parts are getting lubrication is when the oil pressure gauge registers pressure (5 psi - 34.5 kPa) at idle speed. If there is no oil pressure indicated within 10 to 15 seconds, stop the engine and check the lubricating system. The pressure should not fall below 28 psi (193 kPa) at 1800 rpm, and normal operating pressure should be higher. If pressure does not fall within these guidelines, it should be checked with a manual gauge.



CAUTION:

To avoid personal injury from the hot oil, do not operate the engine with rocker covers removed for any reason.

Warm-up

Run the engine at part throttle for about five (5) minutes to allow it to warm up before applying a load.

Inspection

Transmission, Marine Gear—While the engine is idling, check the transmission or marine gear for proper oil level and add oil as required. On marine

engines check that water is flowing out the exhaust pipe or raw water discharge pipe. Look for coolant, fuel, or lubricating oil leaks at this time. If any are found, shut down the engine immediately and have leaks repaired after the engine has cooled.

Cooling System—Entrapped air **must** be purged after the cooling system is filled. To do this allow the engine to warm up without the pressure cap installed. With the transmission or marine gear in neutral, increase engine rpm above 1000 rpm and add coolant as required. Vent the petcock on the water return line at the water-jacketed turbocharger (if used) until coolant (no air) comes out. Install the pressure cap after the coolant level has stabilized at the bottom of the radiator or heat exchanger tank filler neck. Refill the recovery bottle as needed if coolant is drawn into the engine while purging the air.

If all of the coolant is drawn out of the recovery bottle when the engine cools, remove the pressure cap from the radiator or heat exchanger and check to make sure the coolant level is at the bottom of the filler neck. Add coolant as required, replace the pressure cap, and fill the recovery bottle to the "Full Cold" level, or no more than one-quarter of its volume.

NOTICE:

Failure to properly fill the cooling system and purge it of air can result in engine overheating and serious engine damage.

Do not overfill the recovery bottle, since this can result in spillage as the coolant expands during engine operation.

Crankcase—If the engine oil was replaced, stop the engine after normal operating temperature has been reached. Allow the oil to drain back into the crankcase for approximately twenty (20) minutes, and check the oil level. If necessary, add oil to bring the level to the proper mark on the dipstick. Use only the heavy-duty oils recommended in **How to Select Lubricating Oil** (page 45) in this guide.

Turbocharger—Make a visual inspection of the turbocharger for oil leaks, coolant leaks, exhaust leaks, excessive noise or vibration. Stop the engine immediately if a leak or unusual noise or vibration is noted. **Do not restart the engine until the cause of the concern has been investigated and corrected.** Authorized Detroit Diesel service outlets are properly equipped to perform this service.



CAUTION:

To avoid personal injury or turbocharger damage, do not remove, attach, or tighten turbocharger air intake ducting while the engine is operating or operate the engine with the ducting removed.

Avoid Unnecessary Idling

During long engine idling periods with the transmission in neutral, the engine coolant temperature may fall below the normal operating range. The incomplete combustion of fuel in a cold engine will cause crankcase oil dilution, formation of lacquer or gummy deposits on the valves, pistons, and rings, and rapid accumulation of sludge in the engine. When prolonged idling is necessary, maintain at least 800-1000 rpm.

NOTE: On coach engines equipped with Delco 50 DN alternators and mechanical unit injectors the optimum low idle speed setting with full accessory load and the transmission in neutral is:

6V-92 — 650 rpm

8V-92 — 550 rpm

Stopping the Engine

Normal Stopping

1. Reduce engine speed to normal idle and put all shift levers in the *neutral* position.
2. Allow the engine to run between idle and 1,000 rpm with no load for four (4) or five (5) minutes. This allows the engine to cool and permits the turbocharger to slow down. After four or five minutes, shut down the engine.

NOTICE:

Stopping a turbocharged engine immediately after high speed operation may cause damage to the turbocharger, as it will continue to turn without an oil supply to the bearings.

Emergency Stopping

The emergency shutdown should be used only when the engine does not respond to the normal stop engine procedure.

To shut down the engine, simply activate the emergency shutdown control. This is an electrical switch or mechanical lever which is normally identified as such on the control panel.

NOTICE:

Never use the emergency shutdown system, except in an emergency. Use of the emergency shutdown can cause lubricating oil to be sucked past the oil seals and into the blower and may also cause turbocharger damage.

The air shutdown, located in the air inlet housing, must be reset by hand and the **“emergency stop”** knob pushed in before the engine is ready to start again.

NOTICE:

If the emergency air shutdown is used to stop the engine in an emergency situation, always have the shutdown checked for damage and for proper operation before the vehicle, vessel, or machine is returned to service. This is especially important if shutdown is made at high engine rpm. To ensure positive valve closure should another emergency shutdown be required, the shutdown **must** be checked and required repairs or adjustments made at this time.

Failure to observe this precaution may permit engine run-on when the emergency shutdown is activated.

Emergency Jump Starting

Use the following procedure to start the engine of a vehicle with a “low battery” or one that will not crank the engine fast enough to start.

NOTICE:

Do not use this procedure if the battery of the disabled vehicle will not accept a charge or is frozen. Attempting to start the vehicle under these conditions may result in cranking system damage.

The DDEC II electronic control system operates on 12 volts DC. If a DDEC II engine with an electric starting motor requires emergency jump starting, do not exceed 16 volts DC.

The DDEC III electronic control system operates on 12 or 24 volts DC. If a DDEC III engine with an electric starting motor requires emergency jump starting, do not exceed 32 volts DC.

NOTICE:

Jump starting with voltages greater than those indicated *or* reversing battery polarity may damage the ECM (electronic control module).



CAUTION:

The following procedure must be performed exactly as outlined. Failure to observe precautions and/or follow this sequence may result in injury to the face, eyes, body, limbs, and respiratory system caused by fire or acid from battery explosion. Property damage could also result.



CAUTION:

Reversing battery polarity can also result in personal injury caused by the sudden discharge of electrolyte from the battery vents and/or the sudden rupture of the battery case caused by explosion of internal hydrogen gas.

1. Prevent shorting of the system by removing metal rings, watches, or jewelry and not allowing metal tools to contact the positive terminal of the battery.
2. Place the transmission of the disabled vehicle in neutral, set the parking brake, and turn the ignition to the *off* position.
3. Turn off lights, heater, air conditioner, and any other electrical loads in the disabled vehicle and the booster vehicle.
4. Wear eye protection if available, or shield eyes when near either battery.
5. Do not allow vehicle bodies or bumpers to touch.
6. Connect one end of the first jumper cable to the positive (+) terminal of the dead battery. Connect the other end to the positive (+) terminal of the booster battery.
7. Connect one end of the second jumper cable to the negative (-) terminal of the booster battery. Connect the other end to an engine bolt head or good metallic contact (ground) on the disabled vehicle.

**CAUTION:**

To avoid a spark, do not attach the cable end to the negative terminal of the disabled battery. A spark could cause explosion of gases normally present around the battery, resulting in battery rupture and possible personal injury and/or property damage.

8. Start the engine of the booster vehicle and allow it to run for a minute or two to help charge the battery of the disabled vehicle.
9. Turn the ignition of the disabled vehicle to the *on* position and attempt to start the engine.
10. As soon as the engine starts, remove jumper cables in reverse order of attachment (negative ground cable on newly started engine *first*, then negative cable, then positive cable).
11. Allow the engine to warm up before putting a load on the vehicle.

DDEC OPTIONS

Vehicle, Industrial Engines

Engines having Detroit Diesel Electronic Controls (DDEC) can be equipped with a variety of options designed to warn the operator of an engine malfunction. The options can range from "Check Engine" and "Stop Engine" panel lights to automatic reduction in engine power followed by automatic engine shutdown. The power-down/shutdown option may be activated by low coolant level, low oil pressure or high engine oil or coolant temperature.

To start a DDEC engine be sure the transmission is in neutral or park and turn the ignition key on.

You will notice that both the "Check Engine" and "Stop Engine" lights will come on. This is the result of the DDEC computer diagnosing the system to ensure everything is functional, including the light bulbs for the "Check Engine" and "Stop Engine" warning lights. If everything is okay, both lights will go out in approximately five seconds.

With foot OFF the foot pedal, start the engine *after* the lights go out.

NOTICE:

If the warning lights stay on, or if they do not come on momentarily after starting the engine, consult with a DDEC technician. Operating the engine under these circumstances may result in engine damage.

The DDEC engine is equipped with an electronically controlled fuel injection system.

DDEC engines have the ability to perform diagnostics for self-checks and continuous monitoring of other system components. Depending on the application, DDEC can also monitor oil temperature, coolant temperature, oil pressure, fuel spill pressure, coolant level, and remote sensors (if used). This diagnostic system is connected to the "Check Engine" and "Stop Engine" lights to provide a visual warning of a system malfunction.

The DDEC engine can be equipped with an engine protection system that features a 30 second, stepped-power shutdown sequence or an immediate speed reduction without shutdown in the event a

major engine malfunction occurs, such as low oil pressure, high oil temperature, or low coolant level.

NOTICE:

If the engine is equipped with the power-down/shutdown option, there will be a system override button or switch which may be used to allow engine operation for a short period of time. If the shutdown override button is not used, the shutdown will occur in 30 seconds.

DDEC engines may also have an optional 3-100 minute idle shutdown system. The purpose of this system is to conserve fuel by eliminating excessive idling and to allow for a turbocharger cool down period. To activate the shutdown, the transmission must be in neutral, with the engine in idle or PTO mode.

Cruise Control

A DDEC-equipped vehicle engine may have cruise control. Cruise control is available at either a road speed or engine speed setting. The driver has switches to activate and deactivate the system, and a slight depression of the brake or clutch pedal deactivates the system as well. The minimum speed at which cruise control can be used is 30 or 35 mph (depending on vehicle specifications) and 1200 rpm.

The cruise control may also be programmed to permit fast idle using the cruise control switches. With the engine at normal idle, transmission in neutral and service brake on, turn on the cruise control "on/off" switch, and use the "set" switch. The engine rpm

should increase to a pre-defined rpm. The rpm can be raised or lowered from this point using the "set" and "resume" switches.

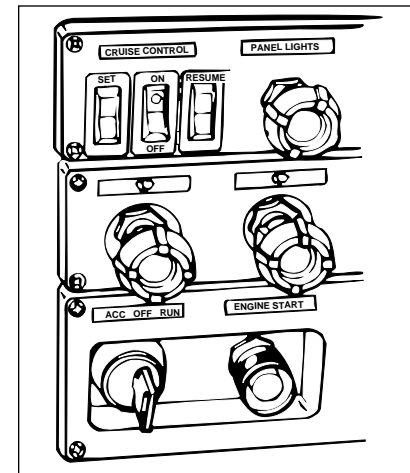

Typical Cruise Control Switches

The cruise control option will maintain the set speed under normal road and load conditions. It cannot limit vehicle speeds on down grades if available engine braking effort is exceeded, nor can it maintain speed on upgrades if power requirements exceed engine power capability.

NOTICE:

When descending a hill with cruise control "on" or "off," do not allow the engine to exceed 2300 rpm under any conditions. Failure to observe this precaution can result in overspeeding and serious engine damage.



CAUTION:

To avoid the possibility of vehicle damage and/or personal injury, Detroit Diesel does not recommend using cruise control under the following conditions:

- **When it is not possible to keep the vehicle at a constant speed (on winding roads, in heavy traffic, in traffic that varies in speed, etc.).**
- **On slippery roads (wet pavement, ice or snow-covered roads, loose gravel, etc.).**

On engines equipped with Jacobs Engine Brakes, the "Jake Brake" circuit can be activated by releasing the EFPA (Electronic Foot Pedal Assembly) completely to the idle position. The "Jake Brake" will then operate the same as on engines with mechanical governors. To return the vehicle to cruise speed after brake or clutch application, simply activate the "Resume" switch. Each subsequent touch of the "Resume" switch will increase cruise speed by 1 mile (1.6 km) per hour.

DDEC Operation

Since the DDEC system is electronic, a battery is required to operate the computer.

The system operates at 12 volts. However, in the event of a power supply malfunction, the system will continue to operate at reduced voltage.

At reduced voltage, the electronic control system will detect a malfunction. When this occurs the "Check Engine" light (CEL) will come on.

At this point, the Electronic Control Module will go into "Back Up Control." You should then notice a change in engine operation, and at this time certain DDEC options, such as cruise control, smoke control, and automatic shutdown, will not function.

The engine will operate only at reduced rpm. You will be able to operate the vehicle at reduced voltage until the battery voltage has reached a point where it will no longer function and the engine will shut down.

You can still operate the vehicle and proceed to your designation when the "Check Engine" light (CEL) comes on. However, a report should be made to a DDEC technician as soon as possible.

NOTICE:

When the "Stop Engine" light comes on, the computer has detected a major malfunction in the engine that requires immediate attention. It is the operator's responsibility to shut down the engine to avoid serious damage.

The "Stop Engine" malfunction is recorded in the Electronic Control Module. With the 30 second shutdown option, the engine will begin a 30 second, stepped, power down sequence until it shuts down completely.

To allow for the possibility of the "Stop Engine" automatic shutdown function being activated while the vehicle is operating in a critical situation, an override is provided.

NOTE: In some applications the "Stop Engine Override" and "Diagnostic Request" switches can be the same.

In this situation the operator may elect to override the automatic stop engine sequence by pressing the

"Stop Engine Override" switch, located on the instrument panel, until a safe stop can be made. The operator only needs to press the override switch every 15 to 20 seconds to prevent engine shutdown from occurring.

NOTICE:

For some applications, holding the "Stop Engine Override" switch in will not prevent the engine shutdown sequence. You must continue to reset the automatic shutdown system by pressing the "Stop Engine Override" switch at intervals of approximately 15 to 20 seconds.

An important thing to remember is that it takes 30 seconds from the time the automatic shutdown sequence begins until engine shutdown. Therefore, the operator **must** press the override switch just prior to engine shutdown and continue to do so until the vehicle can be brought to a safe stop.

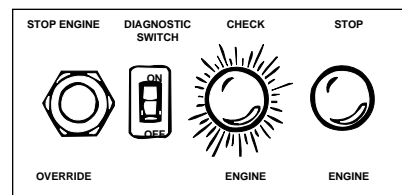

Typical Shutdown Override Switch and Engine Lights

The immediate speed reduction option will bring engine rpm back to a predetermined speed, but will not shut down the engine.

The engine should not be restarted after it has been shut down by the engine protection system unless the problem has been located and corrected.

The conditions that will cause the "Stop Engine" light (SEL) to come on are:

- Loss of coolant
- High oil temperature
- Low oil pressure
- Auxiliary shutdown

It is important to point out that whenever the "Check Engine" light (CEL) or the "Stop Engine" light (SEL) comes on, the DDEC computer will determine where the problem is, and will then store this information in its memory.

If the malfunction is intermittent, the "Lights" will come on and go off as the computer senses the changing engine condition.

A special diagnostic tool (Diagnostic Data Reader, or "DDR") is available that can be plugged into the engine computer memory to extract information related to the cause of the problem.

Once the malfunction has been corrected, the DDEC system will return the engine to normal operation.

The DDR can distinguish between codes now active and those stored in the ECM memory (inactive).

The diagnostic code recorded in the computer memory will remain until it is erased by a technician.

The diagnostic code can also be obtained by the operator:

DDEC II Engines—A “Diagnostic Request” switch is provided which, when pressed, will cause the “Check Engine” light (CEL) to flash a code number. It will, for example, flash twice...pause...flash five times...pause. In other words a code 25.

Code 25 indicates all systems are working satisfactorily.

DDEC III Engines—The **active codes** will be flashed on the “Stop Engine” light (SEL) in the order of most recent to least recent occurrence based on engine hours. If there are no active codes, a code “25” will be flashed.

The **inactive codes** will be flashed on the “Check Engine” light (CEL) in the order of most recent to least recent occurrence based on engine hours. If there are no inactive codes, a code “25” will be flashed.

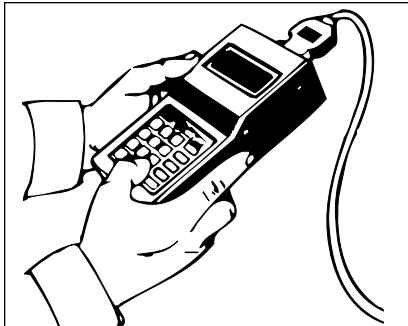

Diagnostic Data Reader J38500

Note that only one lamp will be flashing codes at any time. When code flashing is initiated, the active codes (or code “25”) will be flashed on the SEL. Then the inactive codes (or code “25”) will be flashed on the CEL. When all the inactive codes (or code “25”) have been flashed, the process of flashing all the active codes followed by all the inactive codes will repeat until the conditions for code flashing are no longer satisfied.

The codes will continue to flash and repeat as long as the “Diagnostic Request” switch is held in the “On” position with the ignition on. Other diagnostic codes are shown in the charts (pages 18-19).

NOTICE: If a DDEC II vehicle engine is equipped with an OEM-supplied diagnostic switch, the switch must NOT be switched on when operating the vehicle. If this is done, the diagnostic mode line will be grounded, and the throttle will be forced to idle, affecting vehicle operation. The throttle will also go to idle if pins “A” and “M” in the Diagnostic Data Reader (DDR) connector are jumpered together. This condition will not occur when the Diagnostic Data Reader is used.

Welding Precaution

NOTICE:

To prevent damage to the DDEC electronic control system, disconnect battery power and ground cables and the 6-pin power connector at the ECM (electronic control module) before welding. **Failure to isolate the DDEC system from high current flow can result in severe ECM damage.**



CAUTION:

The operator of a DDEC-equipped engine should know the extent of the warning system on his vehicle, in order to bring it to a safe stop in the event of an engine malfunction. A description of the warning system and detailed instructions regarding its operation should be obtained from the owner, the seller or the manufacturer of the vehicle. This information may also be obtained at any authorized Detroit Diesel service outlet.

To be confronted with a power-down/shutdown situation without knowing how the system works could cause the vehicle to stop in an unsafe location, posing the possibility of damage to the vehicle and a threat to the safety of the operator.



CAUTION:

The operator of a DDEC-equipped vehicle must not attempt to use or read a diagnostic data reader of any kind while the vehicle is operating. Doing so can result in loss of control, which may cause vehicle damage and may result in personal injury.

When engine or electronics system diagnosis is required on a DDEC-equipped vehicle, this must be done by a person other than the operator. The operator must maintain control of the moving vehicle while the assistant performs the diagnosis.

Diagnostic Codes—DDEC II On-Highway and Industrial Engines

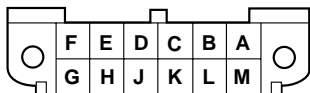

NOTE: DDEC II-equipped engines are designated by the letter "B" in the sixth position of the model number. Example: 80877B28.

TO READ CODES: Use diagnostic data reader or short pin A to pin M. The latter method will flash codes at the CEL.

Diagnostic Connector

Error Code #	Description	Error Code #	Description
11	Power Take-off Sensor Lo Volt	43	Low Coolant Level
12	Power Take-off Sensor Hi Volt	44	Engine Overtemperature
13	Coolant Sensor Lo Volt	45	Low Oil Pressure
14	Eng Temp Sensor Hi Volt	46	Low Battery Voltage
15	Eng Temp Sensor Lo Volt	47	Hi Fuel Pressure
16	Coolant Sensor Hi Volt	48	Lo Fuel Pressure
21	Throttle Pos Sensor Hi Volt	51	EEPROM Error
22	Throttle Pos Sensor Lo Volt	52	ECM - A/D Failure
23	Fuel Temp Sensor Hi Volt	53	EEPROM Memory Fails
24	Fuel Temp Sensor Lo Volt	54	Vehicle Speed Sensor
25	No Codes	55	Proprietary Comm. Link
26	Power Control Enabled	56	ECM - A/D Failure
31	Fault on Auxiliary Output	58	Cruise Ctl/Press Gov Ctl Switch
32	ECM Backup System Failure	61-68	Inj Response Time Long
33	Turbo Boost Sensor Hi Volt	71-78	Inj Response Time Short
34	Turbo Boost Sensor Lo Volt	84	Crankcase Pressure Hi
35	Oil Pressure Sensor Hi Volt	85	Engine Overspeed
36	Oil Pressure Sensor Lo Volt	86	Press Gov Ctl - Hi Volt
37	Fuel Pressure Sensor Hi Volt	87	Press Gov Ctl - Lo Volt
38	Fuel Pressure Sensor Lo Volt		
41	Timing Reference Sensor		
42	Synchronous Ref Sensor		

CEL EXAMPLES

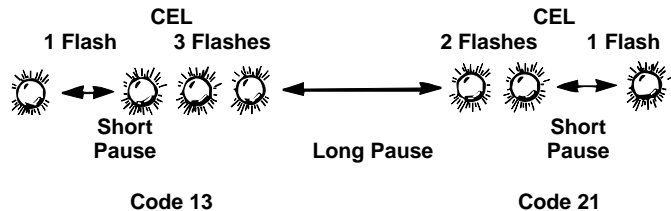

NOTE: The CEL flashing gives both active and historic codes.

Diagnostic Codes—DDEC III On-Highway and Industrial Engines

NOTE: DDEC III-equipped engines are designated by the letter "K" in the sixth position of the engine model number. Example: 80877K28.

TO READ CODES: Use the diagnostic data reader or depress and hold the diagnostic request switch with the ignition on, engine at idle or not running. Press and hold the switch. Active codes will be flashed on the "Stop Engine" light (SEL) followed by the inactive codes being flashed on the "Check Engine" light (CEL). The cycle will repeat until the operator releases the diagnostic request switch.

Flash Code	DDEC Description	Flash Code	DDEC Description
11	PTO input low	46	Battery voltage low
12	PTO input high	47	Fuel pressure high
13	Coolant level circuit low	48	Fuel pressure low
14	Intercooler, coolant or oil temp. circuit high	52	A/D conversion fail
15	Intercooler, coolant or oil temp. circuit low	53	EEPROM write or nonvolatile fail
16	Coolant level circuit high	54	Vehicle speed sensor fault
17	Bypass position circuit high	55	J1939 data link fault
18	Bypass position circuit low	56	J1587 data link fault
21	TPS circuit high	57	J1922 data link fault
22	TPS circuit low	58	Torque overload
23	Fuel temp. circuit high	61	Injector response time long
24	Fuel temp. circuit low	62	Digital output open or short to battery
25	No codes	63	PWM open or short to battery
26	Aux. shutdown #1 or #2 active	64	Turbo speed circuit failed
27	Air temp. circuit high	67	Coolant pressure circuit high or low
28	Air temp. circuit low	68	IVS switch fault, open or grounded circuit
31	Aux. output short or open circuit (high side)	71	Injector response time short
32	SEL short or open circuit	72	Vehicle overspeed
33	Boost pressure circuit high	75	Battery voltage high
34	Boost pressure circuit low	76	Engine overspeed with engine brake
35	Oil pressure circuit high	81	Oil level or crankcase pressure circuit high
36	Oil pressure circuit low	82	Oil level or crankcase pressure circuit low
37	Fuel pressure circuit high	83	Oil level or crankcase pressure high
38	Fuel pressure circuit low	84	Oil level or crankcase pressure low
41	Too many SRS (missing TRS)	85	Engine overspeed
42	Too few SRS (missing SRS)	86	Water pump or baro. pressure circuit high
43	Coolant level low	87	Water pump or baro. pressure circuit low
44	Intercooler, coolant or oil temp. high	88	Coolant pressure low
45	Oil pressure low		

RED = SEL SEL/CEL EXAMPLES YELLOW = CEL

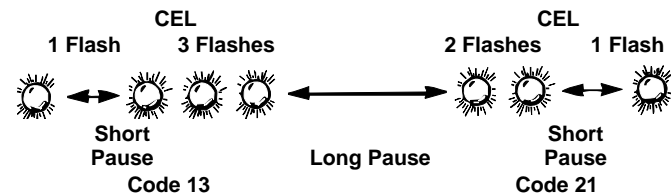

NOTE: The SEL flashing gives active codes. The CEL flashing gives inactive codes.

DDEC II OPTIONS Marine Engines

Marine engines having Detroit Diesel Electronic Controls (DDEC) can be equipped with two display options designed to warn the operator of an engine malfunction. The options are an electronic display module panel displaying critical powertrain parameters or a DDEC imaging system display that includes many vessel functions as well.

The DDEC engine is equipped with an electronically controlled fuel injection system.

DDEC engines have the ability to perform diagnostics for self-checks and continuous monitoring of other system components. Depending on the application, DDEC can also monitor oil temperature, coolant temperature, oil pressure, fuel spill pressure, coolant level, and remote sensors (if used). This diagnostic system is connected to the "Check Engine" and "Stop Engine" lights and the bridge displays to provide a visual warning of a system malfunction.

In the event a major engine malfunction occurs, such as low oil pressure, high oil temperature, low coolant level, or high coolant temperature, the "Stop Engine" and "Check Engine" lights are turned on. The electronic displays at the bridge present the diagnostic code numbers and a brief word description of the fault on the display screen.

DDEC II Operation

Since the DDEC system is electronic, a battery is required to operate the computer.

The system operates at 12 volts. However, in the event of a power supply malfunction, the system will continue to operate at reduced voltage.

At voltage less than 10.5V, the electronic control system will detect a malfunction. When this occurs, the "Check Engine" light will come on and a diagnostic code will show on the bridge display. You may notice a change in engine operation, because DDEC operates with reduced accuracy below 10.5 volts.

You will be able to operate the engine at reduced voltage until the battery voltage has reached a point where it will no longer function and the engine will shut down.

You can still operate the engine and proceed to your destination when the "Check Engine" light (or CEL) comes on. However, a report should be made to a DDEC technician as soon as possible.

NOTICE:

When the "Stop Engine" light comes on or the word "STOP" appears on the screen, the computer has detected a major malfunction in the engine that requires immediate attention. It is the operator's responsibility to shut down the engine to avoid serious damage.

Diagnostic Codes—DDEC II Marine Engines

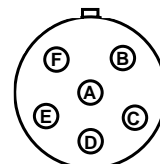

Diagnostic Connector

NOTE: DDEC II-equipped engines are designated by the letter "B" in the sixth position of the engine model number. Example: 80627B00.

TO READ CODES: Use diagnostic data reader or press and hold the diagnostic switch on the BBIM. The latter method will flash codes at the CEL.

Error Code #	Description	Error Code #	Description
11	Hand Throttle Speed Adj Lo Volt	42	Synchronous Ref Sensor
12	Hand Throttle Speed Adj Hi Volt	43	Low Coolant Level
13	Coolant Sensor Lo Volt	44	Engine Overtemperature
14	Eng Temp Sensor Hi Volt	45	Low Oil Pressure
15	Eng Temp Sensor Lo Volt	46	Low Battery Voltage
16	Coolant Sensor Hi Volt	47	Hi Fuel Pressure
23	Fuel Temp Sensor Hi Volt	48	Lo Fuel Pressure
24	Fuel Temp Sensor Lo Volt	51	ECM Calibration Memory Failure
25	No Codes	52	ECM A/D Failure
26	External Warning Switch Enabled	53	ECM Nonvolatile Memory Failure
31	Fault on Auxiliary Output	54	Tach Sync Circuit Fault
32	ECM Backup Failure	55	Proprietary Data Link Circuit Fault
33	Turbo Boost Sensor Hi Volt	56	ECM A/D Failure
34	Turbo Boost Sensor Lo Volt	57	To Be Determined
35	Oil Pressure Sensor Hi Volt	58	Auxiliary Switch Circuit Failure
36	Oil Pressure Sensor Lo Volt	61-68	Inj Response Time Long
37	Fuel Pressure Sensor Hi Volt	71-78	Inj Response Time Short
38	Fuel Pressure Sensor Lo Volt	84	Crankcase Pressure - Hi
41	Timing Reference Sensor	85	Engine Overspeed

CEL EXAMPLES

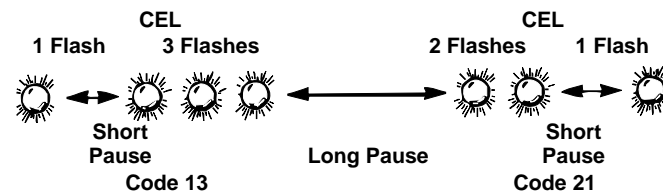

NOTE: The CEL flashing gives both active and historic codes.

The "Stop Engine" malfunction is recorded in the Electronic Control Module for later retrieval by the service technician.

The conditions that will cause the "Stop Engine" light to come on are:

- Loss of coolant
- High oil temperature
- Low oil pressure
- Auxiliary warning

It is important to point out that whenever the "Check Engine" light or the "Stop Engine" light comes on, the DDEC computer will determine where the problem is, and will then store this information in its memory.

If the malfunction is intermittent, the "Lights" will come on and go off as the computer senses the changing engine condition.

A special diagnostic tool (Diagnostic Data Reader, or "DDR") is available that can be plugged into the engine computer data link to extract information related to the cause of the problem.

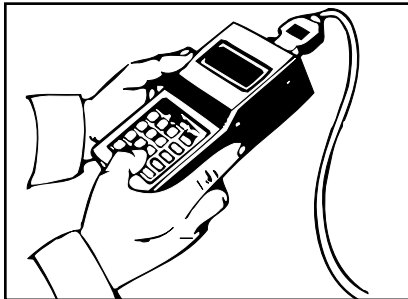

Diagnostic Data Reader J 38500

Once the malfunction has been corrected, the DDEC system will return the engine to normal operation.

The DDR can distinguish between codes now active and those stored in the historic code memory.

The malfunction code recorded in the computer memory will remain until it is erased by a technician.

The historic malfunction codes can also be obtained by the operator. A "Diagnostic Request" switch is located at the BBIM which, when pressed, will cause the "Check Engine" light (or CEL) to flash a code number. It will, for example, flash twice...pause...flash five times....pause. In other words, a code 25.

Code 25 indicates all systems are working satisfactorily.

The codes will continue to flash and repeat as long as the "Diagnostic Request" switch is held in the "On" position with the ignition on. Other diagnostic codes are shown in the chart (page 21).

NOTICE:

The diagnostic switch on the BBIM must NOT be switched on when operating the vessel. If this is done, the diagnostic mode line will be grounded, and fuel injection timing will be altered, affecting engine operation.



CAUTION:

The operator of a DDEC-equipped vessel must not attempt to use or read a diagnostic data reader of any kind while the vessel is operating. Doing so can result in loss of control, which may cause vessel damage and may result in personal injury.

When engine or electronics system diagnosis is required on a DDEC-equipped vessel, this must be done by a person other than the operator. The operator must maintain control of the moving vessel while the assistant performs the diagnosis.



CAUTION:

The operator of a DDEC-equipped engine should know the extent of the warning system on his vessel, in order to bring it to a safe stop in the event of an engine malfunction. A description of the warning system and detailed instructions regarding its operation should be obtained from the owner, the seller or the manufacturer of the vessel. This information may also be obtained at any authorized Detroit Diesel service outlet.

Welding Precaution

NOTICE:

To prevent damage to the DDEC electronic control system, disconnect the following **before** welding: battery power and ground cables and the 6-pin power connector at the ECM (electronic control module). **Failure to isolate the DDEC system from high current flow can result in severe ECM damage.**

ENGINE SYSTEMS

Fuel System

The fuel system consists of the fuel injectors, fuel pipes, fuel manifolds (integral with the cylinder head), fuel pump, fuel strainer, fuel filter, and the necessary connecting fuel lines. The fuel system on DDEC engines also includes electronic fuel system controls and a cooling plate for the electronic control module (ECM).

The primary filter (marked "P") or combination filter and fuel/water separator removes large impurities from the fuel. The secondary filter (marked "S") removes the smaller particles.

Lubrication System

The lubricating oil system consists of an oil pump, oil cooler, full flow oil filter(s), bypass valves at the oil cooler and filter(s), and pressure relief and regulator valves at the lube oil pump.

Air System

In the air system used on Series 92 engines, outside air drawn into the engine passes through the air filter, air silencer, or air separator and is pulled into the turbocharger, where it is compressed. It then moves through the blower, where it is further compressed. An intercooler before the blower, an aftercooler beneath the blower or a charge air cooler in front of the radiator (vehicle engines) may be used to further increase the density of the charge. The air then flows into the cylinders, where it mixes with atomized fuel from the injectors.

Dry type air cleaners are used on the majority of Detroit Diesel engines. For optimum protection of the engine from dust and other airborne contaminants, service these air cleaners when the *maximum allowable air restriction* has been reached, or annually, whichever occurs first.

Cooling System

Radiator/fan cooling systems are used on engines in on-highway, off-highway, industrial, and generator set applications. Heat exchanger/raw water pump systems and keel cooling systems are used on marine engines. Certain generator set applications may also use heat exchangers. Each system has a centrifugal type fresh water pump to circulate coolant within the engine. Each system also incorporates thermostats to maintain normal engine operating temperature.

Electrical System

The electrical system generally consists of a starting motor, starting switch, battery-charging alternator, storage batteries, and the necessary wiring.

Exhaust System

Hot exhaust gas flowing from the exhaust manifold into the exhaust riser is used to drive the turbocharger.

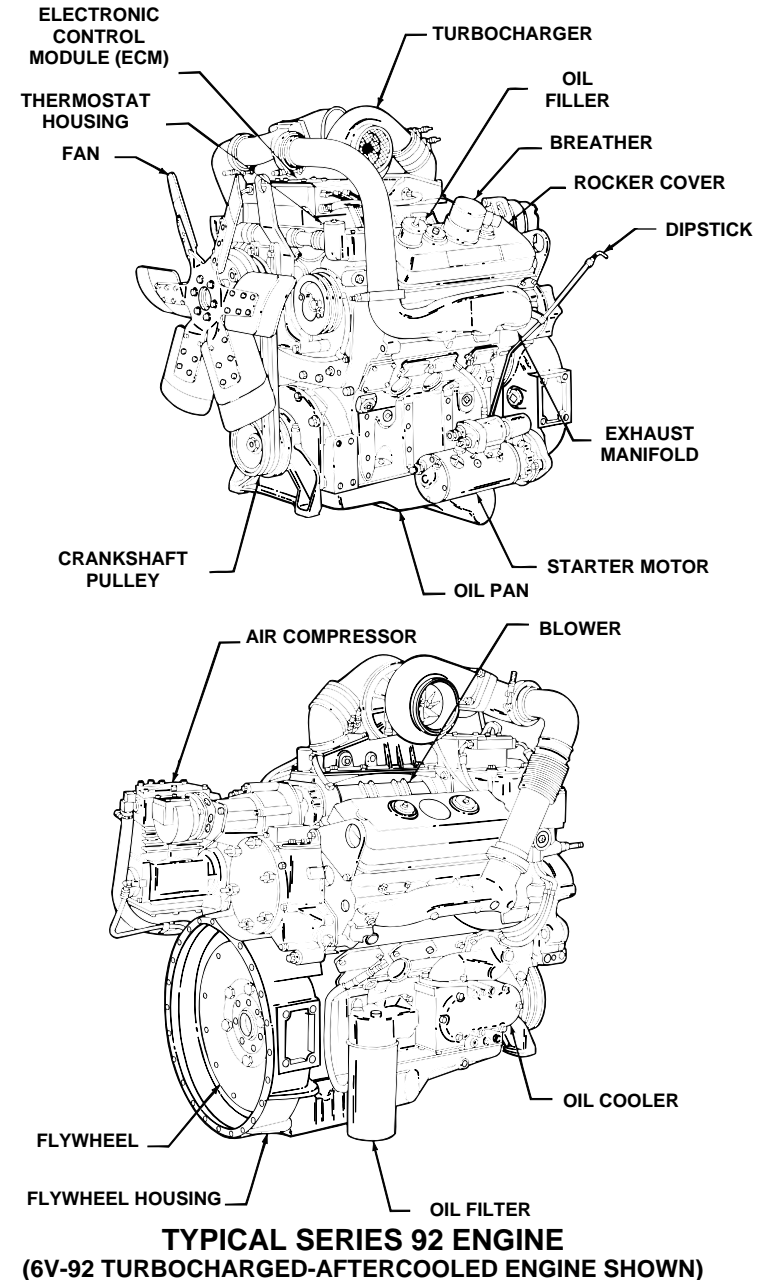

MARINE ENGINE MAINTENANCE

DAILY		SERVICE RECOMMENDATIONS MARINE ENGINES (Continued Next Page)
Lubricating Oil (1)	Ⓘ	
Fuel Tank (2)	Ⓘ	
Fuel Lines and Flexible Hoses (3)	Ⓘ	
Cooling System (4)	Ⓘ	
Turbocharger, Exhaust Conns. (5)	Ⓘ	
Air System, Cleaners* (7)	Ⓘ	
Fuel/Water Separator and Filter* (10)	Ⓘ	
Oil Pressure* (13)	Ⓘ	
Marine Gear* (20)	Ⓘ	
Raw Water Pump* (19)	Ⓘ	
150 HOUR		
Lubricating Oil* (1)	Ⓡ	
Lubricating Oil Filter* (9)	Ⓡ	
Drive Belts (Marine) (8)	Ⓘ	
Cooling System* (4)	Ⓘ	
Fuel/Water Separator and Filter (10)	Ⓡ	
200 HOUR		
Coolant Filter/Inhibitor Level* (11)	Ⓘ	
Codes		
*See Item in Text	Ⓘ Inspect, Service, Correct, Replace (If Necessary)	Ⓡ Replace

NOTE: Numbers after each item refer to the lubrication and preventive maintenance intervals section which follows.

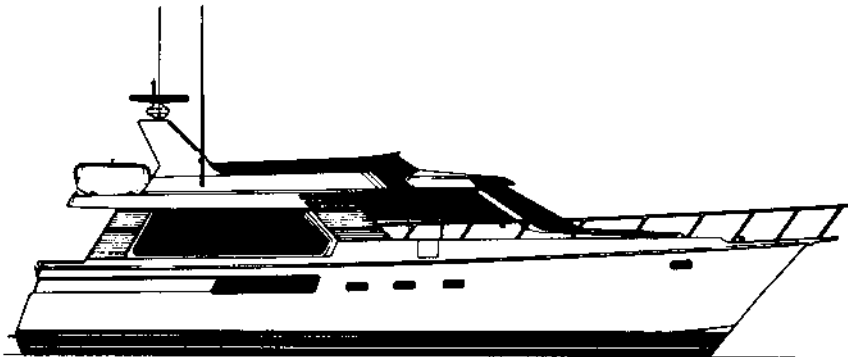

MARINE ENGINE MAINTENANCE

HOURS	150	300	500	1,000	4,000
Fuel Tank (2)					
Fuel Lines and Flexible Hoses* (3)			Ⓘ	Ⓘ	
Cooling System (4)	Ⓘ		Ⓘ		
Drive Belts* (8)	Ⓘ				
Air Cleaner* (7)			Ⓘ		
Air Separators* (7)			Ⓡ		
Fuel Filters* (10)	Ⓡ				
Water Pump, Seal* (11)					
Tachometer Drive (22)		Ⓘ			
Air System (7)					
Turbocharger, Exhaust Connections (5)*					
Engine (Steam Clean) (34)*					
Oil Pressure (13)*			Ⓘ		
Battery Charging Alternator* (14)		Ⓘ			
Engine & Transmission Mounts (15)*				Ⓘ	
Closed Crankcase Collectors* (16)				Ⓘ	
Thermostats & Seals* (31)					Ⓡ
Crankcase Breather* (16)				Ⓘ	
Crankcase Pressure* (16)				Ⓘ	
Blower Screen (32)					
Blower Bypass Valve (21)					
Coolant Filter/Conditioner* (11)					
Fuel Lines and Flexible Hoses* (3)					
Air Box Drain Tube* (25)				Ⓘ	
Air Shutdown Valve* (12)			Ⓘ		
Governor, Overspeed Governor (28)			Ⓘ		
Raw Water System Zincs (18)					
Throttle Delay/Fuel Modulator* (29)					
Air Box Check Valves (25)*				Ⓘ	
Marine Gear* (20)				Ⓘ	
Marine Gear Oil Cooler* (20)					Ⓡ
Fuel and Boost Coolers* (35)					Ⓡ
Heat Exchanger* (36)					Ⓡ
Fuel Injectors* (37)				Ⓡ	
Engine Tune-Up* (17)	AS REQUIRED				
Codes					
*See Item in Text	Ⓘ Inspect, Service, Correct, Replace (If Necessary)			Ⓡ Replace	

NOTE: Numbers after each item refer to the lubrication and preventive maintenance intervals section which follows.

VEHICLE ENGINE MAINTENANCE

DAILY		SERVICE RECOMMENDATIONS VEHICLE ENGINES (Continued Next Page)
Lubricating Oil (1)	Ⓘ	
Fuel Tank (2)	Ⓘ	
Fuel Lines and Flexible Hoses (3)	Ⓘ	
Cooling System (4)	Ⓘ	
Turbocharger, Exhaust Conns. (5)	Ⓘ	
3000 MILE INTERVAL		
Battery* (6)	Ⓘ	
6000 MILE INTERVAL		
Drive Belts* (8)	Ⓘ	
Air Compressor (23)	Ⓘ	
Throttle Controls (24)	Ⓘ	
15,000 MILE INTERVAL		
Fuel Tank (2)	Ⓘ	
Overspeed Governor (28)	Ⓘ	
Dry Type Air Cleaner (7)	Ⓘ	
Lubricating Oil* (1)	Ⓔ	
Lubricating Oil Filter* (9)	Ⓔ	
Coolant Filter/Inhibitor Level* (11)	Ⓘ	
Codes		
*See Item in Text	Ⓘ Inspect, Service, Correct, Replace (If Necessary)	Ⓔ Replace

NOTE: Numbers after each item refer to the lubrication and preventive maintenance intervals section which follows.

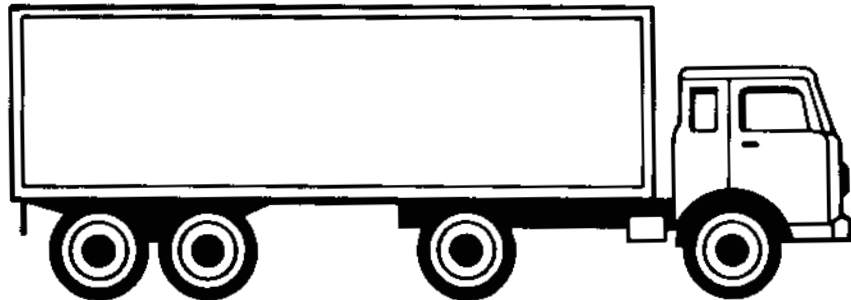

VEHICLE ENGINE MAINTENANCE

MONTHS	6	12	18	24	30	36	42	48	54	60	120	—
MILES 1000 x	10	20	30	40	50	60	70	80	90	100	200	240
Fuel Filters (10)	Ⓔ	Ⓔ	Ⓔ	Ⓔ	Ⓔ	Ⓔ	Ⓔ	Ⓔ	Ⓔ	Ⓔ		
Water Pump* (11)	Ⓘ	Ⓘ	Ⓘ	Ⓘ	Ⓘ	Ⓘ	Ⓘ	Ⓘ	Ⓘ	Ⓘ	Ⓘ	
Fuel Tank* (2)		Ⓘ		Ⓘ		Ⓘ		Ⓘ		Ⓘ		
Cooling System* (4)		Ⓘ		Ⓘ		Ⓘ		Ⓘ		Ⓘ		
Air Compressor* (23)		Ⓘ		Ⓘ		Ⓘ		Ⓘ		Ⓘ		
Air System, Cleaners (7)*		Ⓘ		Ⓘ		Ⓘ		Ⓘ		Ⓘ		
Turbochargers, Exhaust Conns.* (5)		Ⓘ		Ⓘ		Ⓘ		Ⓘ		Ⓘ		
Engine (Steam Clean)* (34)		Ⓘ		Ⓘ		Ⓘ		Ⓘ		Ⓘ		
Radiator* (26)		Ⓘ		Ⓘ		Ⓘ		Ⓘ		Ⓘ		
Oil Pressure* (13)		Ⓘ		Ⓘ		Ⓘ		Ⓘ		Ⓘ		
Battery Charging Alternator* (14)		Ⓘ		Ⓘ		Ⓘ		Ⓘ		Ⓘ		
Thermostats and Seals* (31)		Ⓘ		Ⓘ		Ⓘ		Ⓘ		Ⓘ		Ⓔ
Engine and Transmission Mounts* (15)						Ⓘ						
Crankcase Pressure* (16)						Ⓘ						
Crankcase Breather* (16)		Ⓘ		Ⓘ		Ⓘ		Ⓘ		Ⓘ		
Blower Bypass Valve* (21)										Ⓘ		
Coolant Filter/Inhibitor Level* (11)												
Fuel Lines, Flex Hoses* (3)		Ⓘ		Ⓘ		Ⓘ		Ⓘ		Ⓔ		
Air Box Drain Tube* (25)			Ⓘ			Ⓘ				Ⓘ		
Air Shutdown Valve* (12)		Ⓘ		Ⓘ		Ⓘ		Ⓘ		Ⓘ		
Shutter Operation* (27)		Ⓘ		Ⓘ		Ⓘ		Ⓘ		Ⓘ		
Throttle Delay/Fuel Modulator* (29)					Ⓘ					Ⓘ		
Air Box Check Valves* (25)										Ⓘ		
Fan Hub* (30)		Ⓘ		Ⓘ		Ⓘ		Ⓘ		Ⓘ		
Blower Screen* (32)			Ⓘ									
Engine Tune-Up* (17)												
AS REQUIRED												
Codes												
*See Item in Text	Ⓘ Inspect, Service, Correct, Replace (If Necessary)						Ⓔ Replace					

NOTE: Numbers after each item refer to the lubrication and preventive maintenance intervals section which follows.

STATIONARY AND INDUSTRIAL ENGINE MAINTENANCE

DAILY		SERVICE RECOMMENDATIONS STATIONARY AND INDUSTRIAL ENGINES (Continued Next Page)
Lubricating Oil (1)	Ⓘ	
Fuel Tank (2)	Ⓘ	
Fuel Lines and Flexible Hoses (3)	Ⓘ	
Cooling System (4)	Ⓘ	
Turbocharger, Exhaust Conns. (5)	Ⓘ	
Air Cleaner (Oil Bath) (7)	Ⓘ	
100 HOUR OR 3,000 MILES		
Battery* (6)	Ⓘ	
150 HOUR OR 4,500 MILES		
Lubricating Oil* (1)	Ⓡ	
Lubricating Oil Filter* (9)	Ⓡ	
150 HOUR OR 5,000 MILES		
Air Compressor* (23)	Ⓘ	
200 HOUR OR 6,000 MILES		
Coolant Filter/Inhibitor Level* (11)	Ⓘ	
Drive Belts* (8)	Ⓘ	
Throttle Controls* (24)	Ⓘ	
600 HOURS OR 18,000 MILES		
Water Pump (11)*	Ⓘ	
Codes		
*See Item in Text	Ⓘ Inspect, Service, Correct, Replace (If Necessary)	Ⓡ Replace

NOTE: Numbers after each item refer to the lubrication and preventive maintenance intervals section which follows.

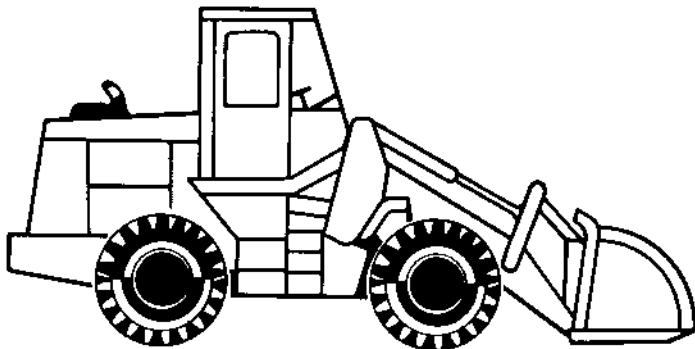

STATIONARY AND INDUSTRIAL ENGINE MAINTENANCE

MONTHS	6	9	12	18	36	60	120
HOURS	300	500	700	1,000	2,000	3,000	6,000
Fuel Tank* (2)		Ⓘ	Ⓘ				
Fuel Lines and Flexible Hoses* (3)		Ⓘ			Ⓡ		
Cooling System* (4)			Ⓘ				
Drive Belts* (8)							
Air Compressor* (23)			Ⓘ				
Air Cleaner* (7)		Ⓘ	Ⓡ				
Fuel Filters* (10)							
Water Pump, Seal* (11)							Ⓡ
Tachometer Drive* (22)						Ⓘ	
Air System* (7)			Ⓘ				
Turbocharger, Exhaust Connections* (5)			Ⓘ				
Engine (Steam Clean)* (34)			Ⓘ				
Radiator* (26)			Ⓘ				
Oil Pressure* (13)			Ⓘ				
Battery Charging Alternator* (14)			Ⓘ				
Engine & Transmission Mounts* (15)					Ⓘ		
Thermostats & Seals* (31)							Ⓘ
Crankcase Breather* (16)				Ⓘ			
Crankcase Pressure* (16)				Ⓘ			
Blower Screen* (32)					Ⓘ		
Blower Bypass Valve* (21)						Ⓘ	
Coolant Filter/Inhibitor Level* (11)							
Fuel Lines and Flexible Hoses* (3)							Ⓡ
Air Box Drain Tube* (25)				Ⓘ			
Air Shutdown Valve* (12)		Ⓘ	Ⓘ				
Governor, Overspeed Governor* (28)		Ⓘ					
Shutter Operation* (27)			Ⓘ				
Raw Water System Zincs* (18)							
Throttle Delay/Fuel Modulator* (29)							
Air Box Check Valves* (25)							Ⓘ
Fan Hub* (30)			Ⓘ				
Fuel and Boost Coolers* (35)							
Heat Exchanger* (36)							
Fuel Injectors* (37)							
Engine Tune-Up* (17)							AS REQUIRED
Codes							
*See Item in Text	Ⓘ Inspect, Service, Correct, Replace (If Necessary)			Ⓡ Replace			

NOTE: Numbers after each item refer to the lubrication and preventive maintenance intervals section which follows.

LUBRICATION AND PREVENTIVE MAINTENANCE INTERVALS

The following is intended as a guide for establishing preventive maintenance intervals. The recommendations given should be followed as closely as possible to obtain long life and optimum performance from Series 92 engines. Intervals indicated on the chart are time (hours or mileage) of actual operation.

The intervals shown apply only to the maintenance functions described. These functions should be coordinated with other regularly scheduled maintenance.

The “daily” instructions apply to routine or daily starting of an engine. They do not apply to a new engine or one that has not been operated for a considerable period of time. For new or stored engines, refer to the engine service manual (6SE379). Follow instructions given under **Preparations for Starting the Engine the First Time** (section 13.1).

Preventive maintenance other than the “daily” checks should be performed by authorized Detroit Diesel service outlets. These outlets have the trained personnel and special tools to properly perform all services.

Item 1 - Lubricating Oil

Check the oil level daily with the engine stopped. On coach engines equipped with running level dipsticks, this may be done with the engine at idle and at operating temperature. If necessary, add sufficient oil to raise the level to the proper mark on the dipstick. All diesel engines are designed to use some

oil, so the periodic addition of oil is normal.

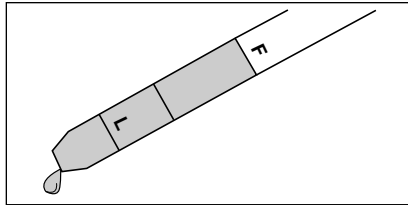

Check Oil Level Daily

NOTICE:

If the oil level is constantly above normal and excess lube oil has not been added to the crankcase, consult with an authorized Detroit Diesel service outlet for the cause. Fuel or coolant dilution of lube oil can result in serious engine damage.

For lubricating oil change intervals, refer to “When to Change Oil” in the **How To** section of this guide. Before adding lube oil, refer to “How to Select Lubricating Oil” in the **How To** section.

Item 2 — Fuel and Fuel Tank

Keep the fuel tank filled to reduce condensation. Before adding fuel, refer to **How to Select Fuel Oil** in the **How To** section of this guide.

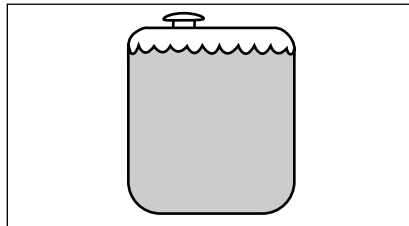

Keep Tank Filled to Reduce Condensation

Refill the tank at the end of each day's operation to prevent condensation from contaminating the fuel. Condensation formed in a partially filled tank promotes the growth of microorganisms that can clog fuel filters and restrict fuel flow. To prevent microbe growth add a biocide to the fuel tank or primary fuel supply. Follow manufacturer's usage, handling, and safety recommendations.

Water accumulation can be controlled by mixing isopropyl alcohol (dry gas) into the fuel oil at a ratio of one pint (0.5 liter) per 125 gallons (473 liters) fuel (or 0.10% by volume).

Detroit Diesel does not recommend adding alcohol to fuel used in marine engines.

Open the drain at the bottom of the fuel tank every 30,000 miles or 48,000 km (300 hours for industrial applications) to drain off any water and/or sediment.

Every 12 months or 120,000 miles (192,000 km) (600 hours for industrial applications) tighten all fuel tank mountings and brackets. At the same time, check the seal in the fuel tank cap, the breather hole in the cap and the condition of the flexible fuel lines. Repair or replace the parts, as necessary.

NOTICE:

A galvanized steel tank should never be used for fuel storage, because the fuel oil reacts chemically with the zinc coating to form powdery flakes which can quickly clog the fuel filters and damage the fuel pump and injectors.

Item 3 — Fuel Lines, Flexible Hoses

Pre-Start Inspection—Make a visual check for fuel leaks at all engine-mounted fuel lines and connections, and at the fuel tank suction and return lines. Since fuel tanks are susceptible to road hazards, leaks in this area may best be detected by checking for accumulation of fuel under the tanks. Check hoses daily as part of the pre-start inspection. Examine hoses for leaks, and check all fittings, clamps, and ties carefully. Make sure that hoses are not resting on or touching shafts, couplings, heated surfaces including exhaust manifolds, any sharp edges, or other obviously hazardous areas. Since all machinery vibrates and moves to a certain extent, clamps and ties can fatigue with age. To ensure continued proper support, inspect fasteners frequently and tighten or replace them as necessary.

If fittings have loosened or cracked or if hoses have ruptured or worn through, take corrective action immediately. Leaks are not only potentially detrimental to machine operation, but they can also result in added expense caused by the need to replace lost fluids.



CAUTION:

Personal injury and/or property damage may result from fire due to the leakage of flammable fluids such as fuel or lube oil.

Service life—A hose has a finite service life. With this in mind, all hoses should be thoroughly inspected at least every 500 operating hours (1,000 hours for fire-resistant fuel and lubricating oil hoses) and/or annually. Look

for cover damage and/or indications of twisted, worn, crimped, brittle, cracked, or leaking lines. Hoses with their outer cover worn through or damaged metal reinforcement should be considered unfit for further service.

All hoses in and out of machinery should be replaced during major overhaul and/or after a maximum of five years of service.

EXCEPTION: Replace all cooling system hoses on pleasure craft marine engines after 1,000 hours of service, regardless of apparent condition. Cooling system hoses on commercial marine engines do not require automatic replacement after 1,000 hours, but should be replaced at overhaul.

Fire resistant fuel and lube oil hose assemblies do not require automatic replacement after five years service or at major overhaul, but should be inspected carefully before being put back into service.

Item 4 - Cooling System

	CAUTION:
<p>Do not remove the pressure control cap from the radiator or heat exchanger or attempt to drain the coolant until the engine has cooled. Once the engine has cooled, use extreme caution when removing the cap. The sudden release of pressure from a heated cooling system can result in a loss of coolant and possible personal injury (scalding, eye injury, etc.) from the hot liquid.</p>	

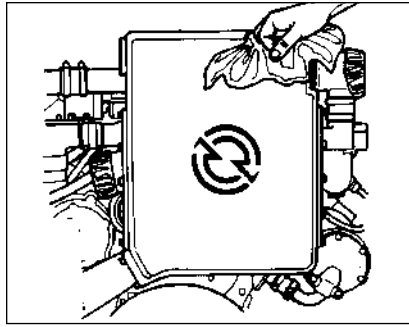

Remove Radiator or Heat Exchanger Pressure Control Cap with Caution

Check the coolant level daily and maintain it near the bottom of the filler neck on the radiator or heat exchanger. On some installations this is done by checking an overflow bottle or sight glass. Add coolant as necessary, but do not overfill. Before adding coolant, refer to **How to Select Coolant** in the **How To** section of this guide.

Make a daily visual check for cooling system leaks. Look for an accumulation of coolant when the engine is running and when it is stopped. Coolant leaks may be more apparent on an engine when it is cold.

The inhibitors in antifreeze solutions should be replenished with a non-chromate corrosion inhibitor supplement when indicated by testing the coolant. Refer to **How to Select Coolant** for required test intervals and inhibitor levels.

Coolant Drain Interval—Detroit Diesel recommends replacing coolant with genuine Detroit Diesel Power Cool antifreeze or equivalent quality ethylene glycol-base permanent type antifreeze annually. However, a cooling system properly maintained and protected with supplemental corrosion inhibitors can be operated up to two years, 4000 hours,

or 200,000 miles (320,000 km), whichever comes first. At this interval, the coolant *must* be drained and the cooling system cleaned thoroughly. The cooling system should then be replenished with **Power Cool** or an equivalent quality ethylene glycol base antifreeze/ water solution in the required concentration. If **Power Cool** or equivalent fully formulated pre-charged inhibited ethylene glycol (IEG) antifreeze *is not* used, required Detroit Diesel Maintenance Product cooling system inhibitors must be added at initial fill. Inhibitor levels must be checked at regular intervals and a new maintenance element installed, if required. Refer to "Inhibitor Test Procedures" under **How to Select Coolant** and use the required coolant filter/conditioner elements shown on the **Specifications** chart (pages 73-74).

Cooling System Hoses—All cooling system hoses should be inspected at least every 500 hours for signs of deterioration and replaced, if necessary.

Raw Water Cooling System- Drain at the end of each boating season.

Sea Strainers- Inspect sea strainers daily. Clean sea strainers at least annually. Clean more often if surface seaweed growth or water contamination levels are fairly high.

Item 5 - Turbocharger, Exhaust Connections

Visually inspect the mountings, intake and exhaust ducting and connections for leaks daily. Check the oil inlet and outlet lines for leaks or restrictions to oil flow. Check for unusual noise or vibration and, if excessive, stop the engine and do not operate until the cause is determined.

Every 12 months, 700 hours or 20,000 miles (32,000 km), the exhaust

manifold retaining nuts, exhaust flange clamp and other connections should be checked for tightness. Check for proper operation of the exhaust pipe rain cap, if one is used.

Check heat-insulating exhaust system blankets for damage daily. Torn, matted, crushed, oil-soaked, or otherwise damaged insulation blankets *must* be replaced immediately.

	CAUTION:
<p>To avoid personal injury or turbocharger damage, do not remove, attach, or tighten turbocharger air intake ducting while the engine is operating or operate the engine with the ducting removed.</p>	

Item 6 - Battery

	CAUTION:
<p>To avoid possible personal injury and/or engine damage from accidental engine startup, always disconnect the battery before servicing the electrical system. To avoid alternator damage when removing battery connections, disconnect the negative (-) terminal first. Reconnect the negative terminal last.</p>	

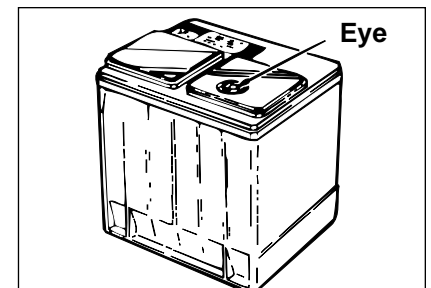

Check "Eye" of Maintenance-Free Batteries

Check the hydrometer "eye" of maintenance-free batteries for charge. If lead-acid or low maintenance batteries are used, check the specific gravity of each cell every 150 hours. Check more frequently in warm weather due to the more rapid loss of water through evaporation. Maintain the electrolyte level according to the battery manufacturer's recommendations, but do not overfill. Overfilling can cause poor performance or early failure.

Keep the terminal side of the battery clean. When necessary, wash with a solution of baking soda and water. Rinse with fresh water. Do not allow the soda solution to enter the cells.

Inspect the cables, clamps, and hold-down brackets regularly. Clean and reapply a light coating of petroleum jelly when needed. Have corroded or damaged parts replaced.

If the engine is to be out of service for more than 30 days, remove the batteries and store in a cool, dry place. Keep batteries fully charged, if possible. Replace any battery that fails to hold a charge.

Periodically check battery connections for corrosion and tightness. If necessary, remove connections and wire brush any corrosion from terminals and cable ends. Replace damaged wiring.

Item 7 - Air Cleaners

A clogged air cleaner element will cause excessive intake restriction and a reduced air supply to the engine. This, in turn, can result in increased fuel consumption, inefficient engine operation and reduced engine life.

Do not allow air inlet restriction to exceed 20 inches of water (5.0 kPa) under any operating conditions.

Oil Bath Type. Air cleaner cups and center tubes should be removed, cleaned, and refilled with clean engine

oil every 8 hours (or less, if operating conditions warrant). The frequency of servicing may be adjusted to suit local dust conditions. If heavy rain or snow is encountered, check the air cleaner for an accumulation of water.

The air cleaner element and baffle should be removed and cleaned annually. The body and fixed element in the heavy duty oil bath air cleaner should be serviced every 500 hours or as conditions warrant.

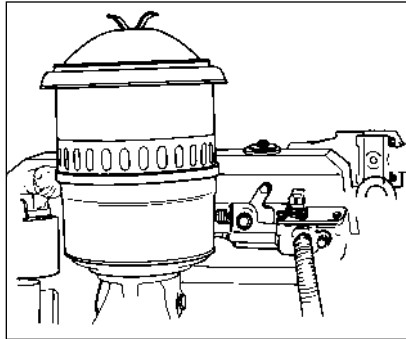

Oil Bath Air Cleaner (Light Duty)

Dry Type. The air cleaner element should be inspected every 15,000 miles (24,000 km) for vehicle engines, 150 hours for non-vehicle engines, or more often if the engine is operated under severe dust conditions. Replace the element if necessary. Check the gaskets for deterioration and replace, if necessary. If the dry type air cleaner is equipped with an aspirator, check for aspirator damage or clogging. Clean and repair as necessary.

Dry-type air cleaner elements should be replaced when the maximum allowable air inlet restriction (20 inches of water or 5.0 kPa) has been reached or annually, whichever comes first. Refer to **When to Service the Dry Type Air Cleaner** (page 60).

Under no engine operating conditions should the air inlet restriction exceed 20 inches of water (5.0 kPa). A clogged air cleaner element will cause excessive intake restriction and a reduced air supply to the engine. This, in turn, can result in increased fuel consumption, inefficient engine operation and reduced engine life.

Inspect the entire air system for leaks daily. Look especially for torn air inlet piping or boots and loose or damaged clamps. Have worn or damaged parts repaired or replaced, as required. Retighten any loose connections.

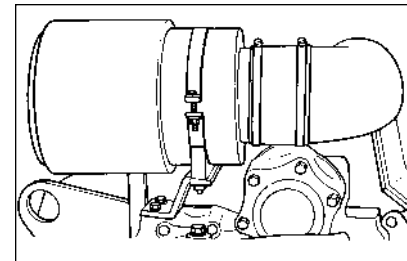

Typical Air Silencer Installation

Air Silencers. Inspect mounting bands and clamps for tightness daily. Clean or replace polyurethane foam elements (socks) annually.

Air Separators (Closed Crankcase Vapor Collectors). Clean and reoil the vacuum limiter and filter element every 250 hours of engine operation. Filter elements and vacuum limiters must also be cleaned and reoiled when the air inlet restriction indicator turns **red**. This indicates the maximum allowable system restriction has been reached.

Replace filter elements after one year or 500 hours of engine operation, whichever comes first. Replace

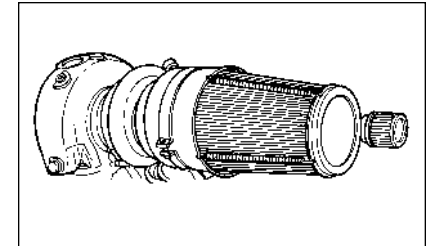

Typical Air Separator Installation

vacuum limiters every 1000 hours of engine operation or every two years, whichever comes first.

Cleaning. If cleaned, filters **must** be cleaned and reoiled with fluids specially designed for this purpose. Authorized Detroit Diesel service outlets are properly equipped to perform these services.

Item 8 — Drive Belts

New standard V-belts will stretch after the first few hours of operation. Run the engine for 10 to 15 minutes at 1200 rpm to seat the belts, then readjust the tension. Check the belts and tighten the fan drive, battery-charging alternator and other accessory drive belts after 1/2 hour or 15 miles and again after 8 hours or 250 miles (402 km) of operation. Thereafter, check the tension of the drive belts every 200 hours (150 hours on marine units) or 6,000 miles (9,600 km) and adjust, if necessary.

Belts should be neither too tight nor too loose. Belts that are too tight impose excess loads on the crankshaft, fan and/or alternator bearings, shortening both belt and bearing life. Excessively overtightened belts can result in crankshaft breakage. A loose belt will slip and may cause damage to accessory components.

Drive belts (V and Poly-V) should be replaced every 2,000 hours or 100,000 miles (160,000 km).

EXCEPTION: Replace belts on pleasure craft marine engines every 1,000 hours of operation, regardless of condition.

Replace ALL belts in a set when one is worn. Single belts of similar size should not be used as a substitute for a matched belt set. Premature belt wear can result because of belt length variation. All belts in a matched belt set are within .032" of their specified center distances.

Use a Belt Tension Gage, such as Kent-Moore tool J 23600-B, (V Belt) or J 23586 (Poly-V Belt) or equivalent, and adjust the belt tension as outlined below.

FAN DRIVE		
ENGINE	ONE BELT	2 OR 3 BELTS
6V, 8V-92	80-100 lbs	60-80 lbs
12V-92		70-90 lbs
16V-92		90-120 lbs
16V-92	10 Rib Poly-V	310-360 lbs
ALTERNATOR DRIVE		
Two 3/8" or 1/2" Belts	One 1/2" Belt	8 Rib Poly-V Belt
40-50 lbs	50-70 lbs	110-130 lbs
AIR COMPRESSOR		
Belt tension is 60 lbs (± 10 lbs) for a single premium high capacity belt (.785" wide) used to drive a 12 CFM air compressor.		

If a belt tension gage is not available, adjust the belt tension so that a firm push with the thumb, at a point midway between the two pulleys, will depress the belt .500"-.750" (12.70-19.05 mm).

When installing or adjusting an accessory drive belt, be sure the bolt at the accessory adjusting pivot point is properly tightened, as well as the bolt in the adjusting slot.

Item 9 - Lubricating Oil Filter

Lubricating oil filters should be changed whenever the engine oil is changed. For oil change intervals, refer to **When to Change Oil** in the **How To** section of this guide. Before changing filters, refer to **How to Replace the Lube Oil Filter** in the **How To** section of this guide. Refer to the **Specifications** section of this guide for required filter part number.

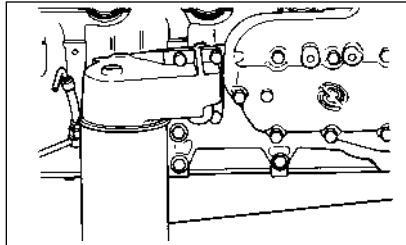

Typical Lubricating Oil Filter Installation

Item 10 - Fuel/Water Separator, Filters

Drain water from fuel/water separator daily or as required. Primary and secondary fuel filters should be replaced every 10,000 miles (16,000 km) or 6 months, whichever comes first (or sooner if plugging is indicated). Refer to the **Specifications** section of this guide for required part numbers. Before changing filters, refer to **How to Replace the Fuel Filter and Strainer** in the **How To** section of this guide.

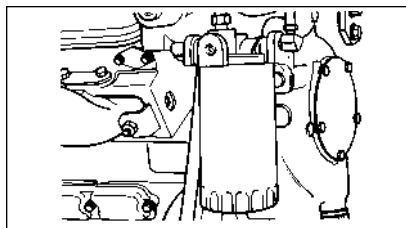

Typical Secondary Fuel Filter Installation

Item 11 - Water Pump and Coolant Filter/Conditioner

Water Pump. The water pump drain hole should be inspected for plugging every 600 hours and cleaned out, if necessary. Authorized Detroit Diesel service outlets are properly equipped to perform this service. The water pump seal should be replaced at engine overhaul or earlier, if leaking is found.

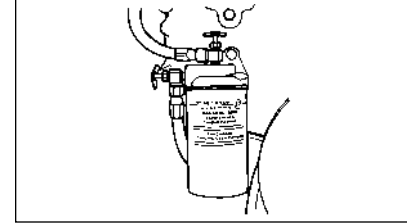

Typical Coolant Filter/Conditioner Element

Coolant Filter. If the cooling system is protected by a coolant filter/conditioner, the coolant must be tested at required intervals and the element replaced, if required. Refer to "Coolant Test Intervals" and "Inhibitor Test Procedures" under **How to Select Coolant** for required test intervals and inhibitor levels. Use the coolant filter/conditioner element part number shown on the **Specifications** chart (page 74).

Item 12 - Air Shutdown Valve

Air shutdown assemblies, whether electrical or manual (pull cable-actuated), **must** be tested for proper operation (with the engine at idle) at least once a year or after 700 hours of engine operation (500 hours on marine units), whichever comes first. The air shutdown valve should be reset in the open position after the check has been made.

NOTICE:
If not adjusted properly, the valve may not close completely when activated, thus defeating its intended purpose to cut off air flow to the engine and shut it down during abnormal operating conditions.

NOTICE:
Do not use the air shutdown for normal or routine engine stopping. Failure to observe this precaution can result in serious engine damage.

NOTICE:
If the emergency air shutdown is used to stop the engine in an emergency situation, always have the shutdown checked for damage and for proper operation before the engine is returned to service. This is especially important if shutdown is made at high engine rpm. To ensure positive valve closure should another emergency shutdown be required, the shutdown must be checked and required repairs or adjustments made at this time. **Failure to observe this precaution may permit engine run-on when the emergency shutdown is activated.**

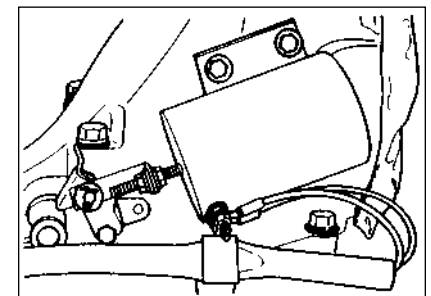

Typical Air Shutdown Cam, Latch, and Solenoid

Item 13 - Oil Pressure

Under normal operation, oil pressure is noted each time the engine is started. If the engine is equipped with a warning light instead of a pressure gauge, have the oil pressure checked and recorded every 700 hours or 20,000 miles (32,000 km). On marine engines check every 500 hours.

Item 14 - Battery Charging Alternator

Terminals should be checked for corrosion and loose connections and wiring inspected for damaged or frayed insulation. Have wiring repaired or replaced, as required.

Precautions must be taken when working on or around the alternator. The diodes and transistors in the alternator circuit are very sensitive and can be easily destroyed.

1. Avoid grounding the output terminal. Grounding an alternator's output wire or terminal (which is always hot, regardless of whether or not the engine is running) and accidentally reversing the battery polarity will result in equipment damage.
2. Do not reverse battery connections. This can also cause damage.



CAUTION:

Reversing battery polarity can also result in personal injury caused by the sudden discharge of electrolyte from the battery vents and/or the sudden rupture of the battery case caused by explosion of internal hydrogen gas.

3. Never disconnect the battery while the alternator is operating. Disconnecting the battery can result in damage to the alternator diodes. In marine applications which have two sets of batteries, switching from one set to the other while the engine is running will momentarily disconnect the batteries. This can result in equipment damage.
4. If a booster battery is to be used, batteries must be connected correctly (negative to negative, positive to positive) to avoid equipment damage.
5. Never use a fast charger with the batteries connected or as a booster for battery output.

Item 15 - Engine, Transmission, and Marine Gear Mounts

Engine and transmission or marine gear mounting bolts and the condition of the mounting pads should be checked every 2,000 hours or 60,000 miles (96,000 km) (whichever comes first) and tightened or repaired, as required.

Item 16 - Crankcase Breather, Pressure

The externally mounted crankcase breather assembly should be removed and the steel mesh pad cleaned in fuel oil annually (vehicle engines) or every 1,000 hours (5,000 hours on marine engines). The cleaning period may be reduced or lengthened depending on severity of service.

Air Separators (Closed Crankcase Vapor Collectors) on Marine Engines. Clean and reoil the filter and the vacuum limiter every 250 hours of operation. Filters and vacuum limiters must also be cleaned and reoiled when the inlet indicator turns red. Replace filter elements after one year or 500 hours of engine operation, whichever comes

first. Replace vacuum limiters every 1000 hours of engine operation or every two years, whichever comes first. If cleaned, filters must be cleaned and reoiled with fluids especially designed for this purpose. Authorized Detroit Diesel service outlets are properly equipped to perform these services.

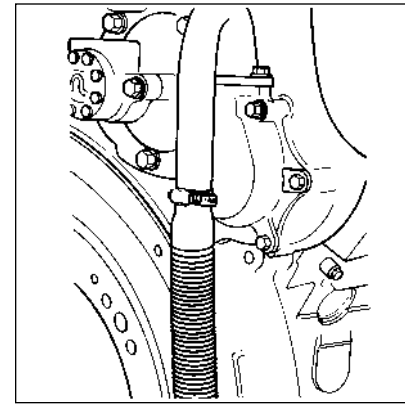

Crankcase Breather Assembly

Crankcase pressure should be checked and recorded every 2,000 hours or 60,000 miles (96,000 km). If an additional crankcase breather collection device is used, crankcase pressure should be recorded with the unit attached and removed.

NOTE: Crankcase pressure of up to 6" H₂O is normal for marine engines equipped with closed crankcase collectors.

Item 17 - Engine Tune-up

There is no scheduled interval for performing an engine tune-up. As long as the engine performance is satisfactory, no tune-up should be needed. Minor adjustments in the valve and injector operating mechanisms, governor, etc. may be required periodically to compensate for normal wear on parts.

Item 18 - Raw Water System Zincs

Heat exchanger "zincs" should be checked initially every 60 hours, then as required or annually. Clean with a wire brush if serviceable. Replace if badly deteriorated. Electrodes are generally found in the heat exchanger assembly, the raw water pump elbows, the fuel and/or boost cooler, and the engine/marine gear auxiliary coolers.

Item 19 - Raw Water Pump

A raw water pump seal malfunction is indicated by leakage of water from the openings in the pump housing. These openings, located between the pump mounting flange and the inlet and outlet ports, must remain open at all times. Leaky seals require replacement. Worn or brittle flexible impellers should be replaced. The raw water pump body or liner should also be checked for cracks or wear and replaced, if necessary. Authorized Detroit Diesel service outlets are properly equipped to perform these services.

Item 20 - Marine Gear

Check marine gear oil level daily. Replace DDC (Twin Disc) marine gear oil, filter, and screen at intervals shown on the chart (page 42). Replace marine gear oil coolers every 4 years or 4,000 hours, whichever comes first.

Item 21 - Blower Bypass Valve

The blower bypass valve should be removed, cleaned in solvent (if necessary), and inspected every 100,000 miles (160,000 km) or 3,000 hours. The valve should be checked for free operation and for scoring on the piston, piston guide, or sleeve

assembly. Have components repaired or replaced as needed.

Item 22 - Tachometer Drive

The tachometer drive should be lubricated every 300 hours at the grease fitting. Use an all-purpose grease (No. 2 grade) at temperatures above 30°F (-1°C). At temperatures below this use a No. 1 grade grease.

Item 23- Air Compressor

Inspect daily for loose fittings, damaged fittings, and coolant leaks.

The polyurethane sponge strainer parts should be removed and cleaned every 150 hours or 5,000 miles (8,000 km), or replaced if not serviceable. (Contact a Bendix or

Midland air compressor dealer for replacement parts.) If reusable, they should be washed in commercial solvent or a detergent and water solution. The element should be saturated in clean engine oil and squeezed dry before being reinstalled.

The air compressor mounting bolts should be tightened every 12 months or 20,000 miles (32,000 km). If belt driven, the belt should be checked for proper tension.

Item 24 - Throttle and Clutch Controls

Inspect daily for loose linkage and tighten as required.

Lubricate the throttle control mechanism every 200 hours or 6,000 miles

(9,600 km). Use an all-purpose grease (No. 2 grade) at temperatures of 30°F (-1°C) and above. Use a No. 1 grade grease at temperatures below this. Lubricate all other control mechanisms, as required, with engine oil.

Item 25 - Air Box Drain Tube

Air flow from the air box drain tubes should be checked every 1000 hours or 30,000 miles (48,000 km) with the engine running. If tubes are clogged they should be removed, cleaned, and reinstalled. Every 100,000 miles (160,000 km) or approximately 3,000 hours the air box check valves should be removed, cleaned in solvent, and the lines should be blown out with compressed air. Inspect for leaks after servicing.

If the engine is equipped with an air box tank, drain the sediment at each oil change.

Item 26 - Radiator

Inspect the outside of the radiator core every 20,000 miles (32,000 km) or 700 hours and, if necessary, clean with a quality grease solvent such as mineral spirits and dry with compressed air.

Do not use fuel oil, kerosene, or gasoline to clean radiator.

	CAUTION:
To avoid personal injury, wear adequate eye protection and do not exceed 40 psi (276 kPa) air pressure.	

Clean the radiator more frequently if the engine is operated in extremely dusty or dirty areas.

Item 27 - Shutter Operation

Check the operation of the shutters and clean the linkage and controls every 20,000 miles (32,000 km).

Item 28 - Governor, Overspeed Governor

The idle speed and no-low speed should be checked and recorded. Have adjusted, as necessary.

An idle speed lower than recommended will cause the engine to be accelerated from a speed lower than the speed at which the engine was certified.

A no-load speed higher than recommended will result in a full-load speed higher than rated and higher than the speed at which the engine was certified.

If the overspeed governor is equipped with a hinge-type cap oiler or oil cup, lubricate with 5 or 6 drops of clean engine oil every 500 hours or 15,000 miles (24,000 km). Avoid excessive lubrication, and do not lubricate while the engine is running.

Item 29 - Throttle Delay, Fuel Modulator

Every 30 months or 50,000 miles (80,000 km) the throttle delay or fuel modulator should be checked and adjusted (if required).

Item 30 - Fan Hub

If the fan bearing hub assembly is provided with a grease fitting, use a hand grease gun and lubricate the bearings with one shot of Mobilgrease HP, or an equivalent lithium-base multi-purpose grease, every 20,000 miles (32,000 km) or approximately 700 hours.

DDC (TWIN DISC) MARINE GEAR LUBE OIL AND FILTER CHANGE REQUIREMENTS

Oil Service Class		
Use API service classification CD, CD-II (CF-2 when available), CE, or CF-4 engine oil which is certified to pass TO2 or TO4 and C-4 specifications or meet the requirements of MIL-L-2104E. Engine oil may be used, provided it meets these requirements.		
Oil Viscosity		
Sump Temperature, also Oil Temperature into Heat Exchanger		Recommended Oil Viscosity
During Start-up	Steady Operating Conditions	
	Below 150°F (66°C)	This operating condition is not approved.
32°F (0°C) Min.	150°—185°F (66-85°C)	SAE viscosity number 40 engine oil 1.12:1—2.54:1
32°F (0°C) Min.	150°—185°F (66-85°C)	SAE viscosity number 40 engine oil 3.10:1—4.95:1
32°F (0°C) Min.	175°—210°F (80-99°C)	SAE viscosity number 40 engine oil 3.10:1—4.95:1
	Above 210°F (99°C)	This operating condition is not approved.
Oil and Filter Change Interval		
First element filter change should take place after 10 hours and thereafter every 1000 hours of operation for both filter element and oil, or 6 months, whichever occurs first.		
Filter Screen		
Remove and clean after first 10 hours and thereafter every 1000 hours of operation, or 6 months, whichever occurs first.		

Every 2,500 hours or 75,000 miles (120,000 km) (vehicle engines) or 4,000 hours (non-vehicle engines) the fan bearing hub assembly should be cleaned, inspected, and re-packed with the grease above.

The bearings in the fan hub assembly should be replaced with new bearings at major engine overhaul. The hub assembly should be packed with Mobilgrease HP or an equivalent lithium-base multi-purpose grease before installing.

Item 31 - Thermostats and Seals

Replace thermostats and seals every 240,000 miles (384,000 km) on vehicle engines. On non-vehicle engines replace every 4,000 hours or two years, whichever comes first and at time of overhaul.

Item 32 - Blower Screen

Have the blower screen and gasket assembly inspected annually (vehicle engines) or every 1,000 hours or 30,000 miles (48,000 km) (non-vehicle engines) and, if necessary, have the screen cleaned in fuel oil and dried with compressed air.



CAUTION:

To avoid personal injury, wear adequate eye protection and do not exceed 40 psi (276 kPa) air pressure.

Item 33 - Power Take-off

Follow the power take-off manufacturer's lubrication and preventive maintenance recommendations at its suggested intervals.

Item 34 - Engine (Steam Clean)

Steam clean the engine and engine compartment every 20,000 miles (32,000 km) or 700 hours.

NOTICE:

Do not apply steam or solvent directly to the battery-charging alternator, starting motor, electrical or DDEC electronic components as damage to electrical equipment may result.

Item 35 - Fuel and Boost Coolers

Replace fuel and boost coolers on marine engines every 4 years or 4,000 hours, whichever comes first. In some applications these are unitized into a single assembly.

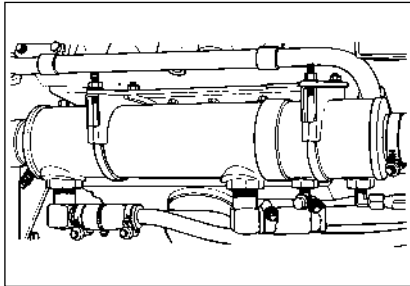

Typical Fuel/Boost Cooler Assembly

Item 36 - Heat Exchanger

Tube and shell type heat exchangers are unitized assemblies with no serviceable components. Replace tube and shell type heat exchangers on marine engines every 4 years or 4,000 hours, whichever comes first.

Item 37 - Fuel Injectors

Replace fuel injectors on pleasure craft marine engines every 1,000 hours of operation. Replace injectors on commercial marine engines every 5,000 hours of operation.

"HOW TO" SECTION

This section covers Detroit Diesel's requirements for selecting lubricating oil, fuel oil, and coolant and includes basic engine maintenance procedures which can be performed by the operator.

NOTICE:

The manufacturer's warranty applicable to Series 92 engines provides in part that the provisions of such warranty shall not apply to any engine unit that has been subject to misuse, negligence or accident. Accordingly, malfunctions attributable to neglect or failure to follow the manufacturer's fuel or lubricating recommendations may not be within the coverage of the warranty.

A. How to Select Lubricating Oil

Lubricant Selection in North America

The selection of the proper lubricating oil is important to achieve the long and trouble-free service which Detroit Diesel engines are designed to provide. The proper lubricating oil for all Detroit Diesel engines is selected

API Symbol:



SAE Viscosity Grade: 40
API Classification: CD II*
Sulfated Ash: Less than 1.0 mass%
*CF-2 when available

based on SAE viscosity grade and API (American Petroleum Institute) service designation. Only oils licensed to display the American Petroleum Institute (API) symbol shown should be used.

Lubricant Requirement

Lubricants meeting these criteria have provided maximum engine life when used in conjunction with recommended oil drain and filter maintenance schedules.

API Performance category CF-2 represents an enhanced level of lubricant performance over the CD-II category which it replaces. Lubricants meeting this new performance level may not be readily available for some time. During this interim period oils labeled as API CD-II may be used.

Only oils licensed by API should be used in Detroit Diesel engines. Certain engine operating conditions may require exceptions to these requirements:

1. For continuous high temperature operation (over 200°F or 94°C Coolant Out), the use of an SAE grade 50 lubricant in all two-stroke cycle engines is required.
2. At ambient temperatures below freezing (32°F or 0°C) sufficient starter cranking speed may not be achieved to start the engine with SAE 40 grade oils. Where starting aids are not available or at very cold temperatures (0 to -25°F or -18 to -32°C) even if starting aids are available, the use of multi-grade SAE 15W-40 or monograde SAE 30 lubricants will improve startability. These lubricants must possess a High Temperature - High Shear Rate Viscosity (measured by ASTM D 4741 or equivalent) of 3.7 cP minimum. **These**

oils must be replaced with mono-grade SAE 40 lubricants as soon as ambient conditions permit.

EXCEPTION: In two-stroke cycle marine engines do not use multi-grade or SAE 30 grade lubricants under any circumstances.

- When the use of high sulfur fuel (greater than 0.5% mass) is unavoidable, the use of lubricants with higher alkalinity is recommended. Be aware that such lubricants may have a sulfated ash content above 1.0% mass. The use of high sulfur fuels also requires modification to oil drain intervals.
- The use of multigrade and/or greater than 1% sulfated ash oils are exceptions for special circumstances. The use of such lubricants in the engine under normal circumstances may not provide satisfactory service life.

Sulfated Ash and Total Base Number

Sulfated ash is a lubricant property obtained by a laboratory test (ASTM D 874) to determine the potential for formation of metallic ash. The ash residue is related to the oil's additive composition and is significant in predicting lubricants which may cause exhaust valve distress under certain operating conditions. Sulfated ash is related to Total Base Number (TBN), also a laboratory test (ASTM D 2896 or D 4739) which measures an oil's alkalinity and ability to neutralize acid. As TBN increases, sulfated ash also increases to where lubricants with TBN's above 10 will likely have sulfated ash contents above 1.0% mass.

Total Base Number is important to neutralize the effects of high sulfur fuel in all diesel engines. For two-stroke cycle engines Detroit Diesel recommends lubricants with sulfated ash contents below 1.0% mass and TBN's between 6 and 10 for engines operating on less than 0.5% sulfur fuel.

When the use of a high ash oil is required, such as with high sulfur fuel, the oil selected should have the highest TBN (D 4739) to Ash (D 874) ratio possible. For example, an oil with a TBN of 10 and an Ash of 1.2% mass is less desirable than an oil with the same TBN and 1.0% Ash.

Synthetic Oils

Synthetic oils may be used in Detroit Diesel engines provided they are API licensed and meet the performance and chemical requirements of non-synthetic oils outlined in this publication. Synthetic oils offer improved low temperature flow properties and high temperature oxidation resistance. However, they are generally more costly than non-synthetic oils.

Product information about synthetic oils should be reviewed carefully. Performance additive systems often respond differently in synthetic oils. Only synthetic oils that do not contain viscosity improver additives may be used in Detroit Diesel two-stroke cycle engines. Their use does not permit extension of recommended oil drain intervals.

The Use of Supplemental Additives

Lubricants meeting the Detroit Diesel specifications outlined in this publi-

SERIES 92 ENGINE MAXIMUM OIL DRAIN INTERVALS	
Fuel Sulfur Below 0.5 % (Normal Operation)	
Service Application	Lube Oil/Filter Change Interval
Highway Truck & Motor Coach	15,000 Miles (24,000 km)
City Transit Coaches	6,000 Miles (9,600 km) or 3 months*
Pick-up & Delivery, Stop & Go and Short Trip Vehicles; Emergency Vehicles, Fire Trucks	12,000 Miles (19,000 km) or 6 months*
Industrial, Agricultural & Marine	150 Hours
Stationary Units Continuous	300 Hours or 3 Months*
Stationary Units Standby	150 Hours or 1 Year*

*Whichever comes first

cation already contain a balanced additive treatment. The use of supplemental additives such as break-in oils, top oils, graphitizers and friction-reducing compounds, are generally not necessary and can even be harmful. These additives may be marketed as either oil treatments or engine treatments and are discouraged from use in Detroit Diesel engines. **Engine damage resulting from the use of such materials is not covered by your Detroit Diesel Corporation warranty.** Detroit Diesel will not provide statements beyond this publication relative to their use.

Lubricant Selection Outside North America

Although the API service classification system is generally utilized worldwide, lubricants meeting Detroit Diesel requirements may not be marketed in all areas of the world. Selection of lubricants in these situations should be made based on viscosity grade first, ash content second, and performance specification third. Oils meeting API CD or CC may be used if they also meet military specification Mil-L-2104 E or F. Modification of oil drain interval may

be necessary, depending on fuel quality. Contact Detroit Diesel Corporation for further guidance.

B. When to Change Oil Oil Drain Intervals

The length of time an engine may operate before an oil change depends upon the lubricant and fuel used, engine oil consumption, and the operating cycle. The table above lists the **maximum** interval which the engine may operate before the oil and filters must be changed. Oil analysis may be used to determine whether this interval should be shortened, but should not be used to lengthen the interval.

The use of fuels with sulfur content above 0.5 mass % will require a shortening of drain intervals and/or the use of a higher TBN oil. For details refer to publication "Engine Requirements—Lubricating Oil, Fuel and Filters" (7SE270), available from authorized Detroit Diesel service outlets.

Disposing of Waste Oil

Dispose of used lubricating oil and filters in an environmentally responsible manner, according to federal (EPA) and/or state recommendations.

The disposal of waste oil may be best addressed by the engine oil supplier, who may accept responsibility for proper disposal of this material as part of the business of providing lubricant.

C. How to Replace the Lube Oil Filter

Filters are an integral part of the lubricating oil system. Proper filter selection and maintenance are important to satisfactory engine operation and service life. Filters should be used to maintain a clean system, not to clean up a contaminated system. Refer to **Specifications** (page 73) for filter part number.

Series 92 engines may use either canister (bolt-on) type or spin-on type lube oil filters.

Replace Canister (Bolt-on) Type Oil Filter

1. Remove the drain plug from the canister shell or the filter adaptor or base and drain the oil into a suitable container.
2. Support the shell, unscrew the center stud, and withdraw the shell, element, and stud as an assembly. Dispose of the oil, element, and shell gasket in an environmentally responsible manner according to state and/or federal (EPA) recommendations.
3. Remove the center stud and gasket. Retain the gasket, unless it is damaged and oil leaks occurred.
4. Remove the nut on the full-flow filter stud.
5. Remove and discard the element retainer seal. Install a new seal.

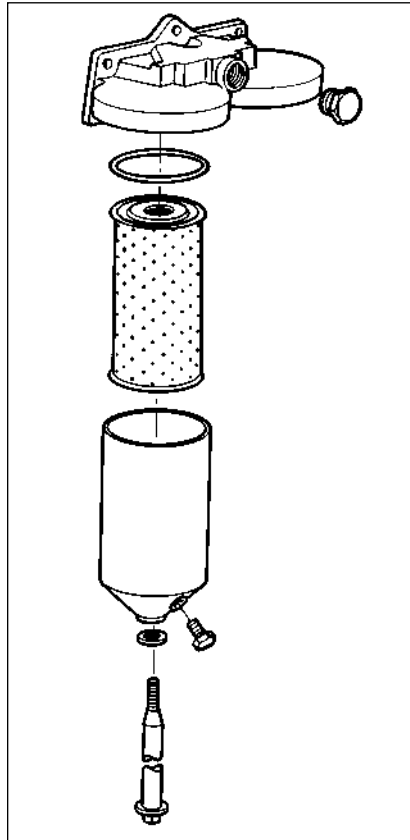

Typical Canister (Bolt-On) Type Oil Filter Assembly

6. Clean the filter shell and adaptor or base.
7. Install the center stud gasket and slide the stud (with the spring, washer, seal and retainer installed on the full-flow filter stud) through the filter shell.
8. Install a new shell gasket in the filter adaptor or base. Before installing the gasket, make sure all old gasket material is removed from the shell and adaptor or base.

9. Remove the paper, plastic, or cellophane wrapping from a new filter element and position the element carefully over the center stud and within the shell. Place the shell/element/center stud assembly in position on the filter adaptor or base, and tighten the stud to 50-60 lb-ft (69-81 N•m) torque.
10. Install the drain plug in the adaptor or base.
11. Add oil as required to bring the level to the "full" mark on the dipstick.
12. Start and run the engine for a short period and check for oil leaks. After correcting oil leaks, stop the engine long enough for the oil from various parts of the engine to drain back to the crankcase (approximately 20 minutes). Add oil as required to bring the level to the proper mark on the dipstick.

NOTICE:

If the oil level is constantly above normal and excess lube oil has not been added to the crankcase, consult with an authorized Detroit Diesel service outlet for the cause. Fuel or coolant dilution of lube oil can result in serious engine damage.

Replace Spin-on Type Oil Filter

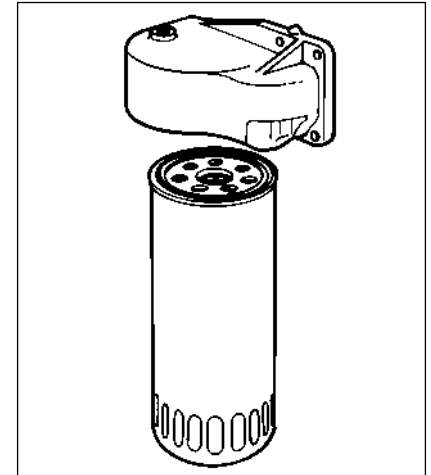

Typical Spin-On Type Oil Filter

1. Remove the spin-on filter cartridge using strap wrench tool J 29917 (or equivalent) and a 1/2" drive socket wrench and extension.
2. Dispose of the used oil and filter in an environmentally responsible manner according to state and/or federal (EPA) recommendations.
3. Clean the filter adaptor with a clean, lint-free cloth.
4. Lightly coat the filter gasket (seal) with clean engine oil.
5. Start the new filter on the adaptor and tighten by hand until the gasket touches the mounting adaptor head. Tighten an additional two-thirds turn.

NOTICE:

Overtightening may distort or crack the filter adaptor.

6. Add oil as required to bring the level to the "full" mark on the dipstick.
7. Start and run the engine for a short period and check for leaks. After any leaks have been corrected, stop the engine long enough for oil from various parts of the engine to drain back to the crankcase (approximately 20 minutes). Add oil as required to bring the level to the proper mark on the dipstick.

NOTICE:

If the oil level is constantly above normal and excess lube oil has not been added to the crankcase, consult with an authorized Detroit Diesel service outlet for the cause. Fuel or coolant dilution of lube oil can result in serious engine damage.

D. How to Select Fuel Oil Quality

Fuel quality is an important factor in obtaining satisfactory engine performance, long engine life, and acceptable exhaust emission levels. Detroit Diesel engines are designed to operate on most diesel fuels marketed today.

In general, fuels meeting the properties of ASTM designation D 975 (grades 1-D and 2-D) have provided satisfactory performance.

The fuels used must be clean, completely distilled, stable, and non-corrosive. For more information regarding the significance of these properties and selection of the proper fuel, refer to publication "Engine Requirements—Lubricating Oil, Fuel, and Filters" (7SE270), available from authorized Detroit Diesel service outlets

Fuel Sulfur Content

The sulfur content of the fuel should be as low as possible to avoid premature wear of piston rings and liners, avoid excessive deposit formation, and minimize sulfur dioxide exhausted into the atmosphere. Limited amounts of sulfur can be tolerated, but the amount in the fuel and engine operating conditions can influence corrosion and deposit formation tendencies. **The use of fuel containing greater than 0.5 mass percent sulfur will require more frequent oil changes.**

All 1994 model year on-highway diesel engines manufactured for use in the United States must meet a new reduced exhaust particulate content of 0.10 gram/horsepower-hour. To meet this requirement, all diesel fuel sold in the United States for **on-highway use** will be limited to 0.05% maximum sulfur content. The sulfur content of diesel fuel for **off-highway use** will continue to be specified at 0.5% maximum. Off-highway fuel will be dyed blue for identification.

NOTE: The use of low sulfur diesel fuel does not permit extension of engine lube oil drain and filter change intervals.

Cold Weather Operation

In cold weather, diesel fuel will form wax crystals which can restrict flow and clog filters. Fuel oil suppliers approach this problem several ways. Some provide a specially refined product, while others may use flow-improving additives or winter blends. Winter blended fuel will likely contain kerosene or 1-D fuel, which provide good cloud point temperatures, but result in a lighter fuel with a lower heat content. These fuels may be

used, but they may result in reduced engine power and/or fuel mileage.

Fuel Cleanliness

Fuel should be clean and free of contamination. Storage tanks and stored fuel should be inspected regularly for dirt, water, or water-emulsion sludge, and cleaned if contaminated. Storage instability of the fuel can lead to the formation of varnish or sludge in the tank. The presence of these contaminants from storage instability must be resolved with the fuel supplier. If fuel is stored on site, the following is recommended:

1. Do not use galvanized steel or sheet metal tanks and galvanized pipes or fittings in any diesel fuel storage, delivery, or fuel system. The fuel oil will react chemically with the zinc coating, forming a compound which can clog filters and cause engine damage.
2. Keep the storage tank filler cap covered to prevent contamination by rain water.
3. Keep the tank clean especially around the filler cap and tap areas.
4. Position the tank so that it is tilted slightly toward the bottom drain. This will make draining of accumulated water and sediment a little easier.
5. Minimize condensation by keeping the tank reasonably filled at all times.
6. After filling the fuel storage tank, wait a few hours before filling equipment tanks to allow contaminants to settle.

Fuel Contamination

Generally, fuel contamination occurs as the result of improper fuel handling. The most common types of contamination are water, dirt, and microbial growth ("black slime"). The formation of varnishes and gums resulting from poor stability or extended storage ("stale fuel") also affects fuel quality. The best treatment for contamination is prevention by maintaining a clean storage system and choosing a reputable fuel supplier.

Fuel Additives

Detroit Diesel engines are designed to operate satisfactorily on a wide range of diesel fuels. Some fuels may be marketed which contain performance additives and are identified as premium diesel fuel. Detroit Diesel engines do not require the use of such fuels; however, they may be used at the customer's discretion.

Aftermarket Supplemental Fuel Additives—There are many aftermarket products available today which are intended to be added to the fuel by the customer. These include a variety of independently marketed products which claim to be:

- Cetane Improvers
- Emission Control Additives
- Detergents
- Combustion Improvers
- Smoke Suppressants
- Cold Weather Flow Improvers

Supplemental additives are not recommended due to potential injector system or engine damage. Our experience has been that such additives increase operating costs without providing benefit.

The use of supplemental fuel additives does not necessarily void the engine warranty. **However, repair expenses which result from fuel system or engine component malfunctions or damage attributed to their use will not be covered.** These products should be accompanied with performance data supporting their merit. It is not the policy of Detroit Diesel Corporation to test, evaluate, approve, or endorse such products.

Some fuel additives provide temporary benefits but do not replace good fuel handling practices. Such additives are helpful when water contamination is suspected:

- **Isopropyl Alcohol** - 1 pint per 125 gallons of fuel for winter freeze-up protection.
- **Biocide** - For treatment of microbe growth or "black slime." Follow manufacturers' instructions for treatment.

Prohibited Additives

The following additives are NOT allowed and MUST NOT be mixed with diesel fuel:

Used Lubricating Oil—Detroit Diesel specifically prohibits the use of drained lubricating oil in diesel fuel. Used lubricating oil contains combustion acids and particulate materials which severely erode injector components, resulting in loss of power and increased exhaust emissions. In addition, the use of drained lubricating oil will increase maintenance requirements due to filter plugging and combustion deposits.

Gasoline—



CAUTION:

The addition of gasoline to diesel fuel will create a serious fire hazard.

The presence of gasoline in diesel fuel will reduce fuel cetane number and increase combustion temperatures. Tanks which contain such mixtures should be drained and cleaned as soon as possible.

Detroit Diesel Corporation will not be responsible for any detrimental effects which it determines resulted from adding used engine oil or gasoline to the diesel fuel.

For more detailed information on fuel requirements, refer to "Engine Requirements—Lubricating Oil, Fuel, and Filters" (7SE270), available from authorized Detroit Diesel service outlets.



CAUTION:

When the temperature of diesel fuel is elevated, as occurs when the fuel is circulated through an operating engine, it may pose the following hazards which should be guarded against.

- **Heated liquid fuel may cause scalding if allowed to come in contact with the skin.**
- **Heated diesel fuel can form combustible vapor mixtures in the area around the fuel source.**

The following precautions should be taken to minimize the possibility of injuries from heated diesel fuel.

1. **Whenever possible, it is recommended that the engine and fuel be given an opportunity to cool down to ambient temperature before performing service operations which could result in the spillage of fuel from the engine or vehicle fuel system. When this is not possible, protective clothing (face shield, insulated gloves, apron) should be worn when performing these operations.**
2. **Keep open flames, sparks or other potential ignition sources away and do not smoke during vehicle refueling and service operations which could result in the escape of liquid or vaporized diesel fuel.**
3. **Engine or vehicle fuel systems service operations should be performed in a well ventilated area that is kept free of bystanders.**

E. How to Replace the Fuel Filter and Strainer

Filters are an integral part of the fuel system. Proper filter selection and maintenance are important to satisfactory engine operation and service life. Filters should be used to maintain a clean system, not to clean up a contaminated system. Refer to **Specifications** (page 73) for proper filter selection.

Series 92 engines use spin-on type fuel filters. The spin-on filter consists of a shell, element, and gasket unitized into a single cartridge and a strainer or filter cover which includes a threaded sleeve to accept the spin-on filter cartridge.

Replace Spin-on Type Filter Element

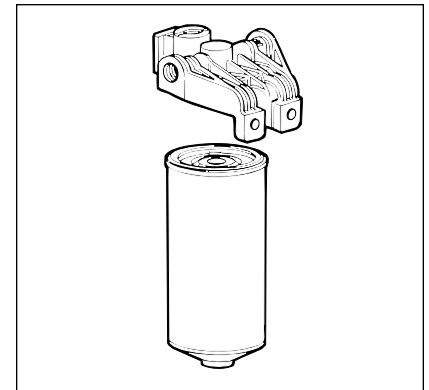

Typical Spin-On Type Fuel Filter or Strainer

1. With the engine shut down, place a suitable container under the strainer or filter and unscrew the cartridge. Dispose of the cartridge in an environmentally responsible manner according to

state and/or federal (EPA) recommendations.

2. Fill a new replacement cartridge about two-thirds full with clean fuel oil. Coat the seal gasket lightly with clean fuel oil.
3. Install the new cartridge and tighten by hand until the gasket touches the mounting adaptor head. Tighten an additional one-half turn.

NOTICE:

Overtightening may distort or crack the filter adaptor.

4. Start the engine and check for leaks.

NOTICE:

To improve engine starting, have replacement elements filled with fuel and ready to install immediately after used elements are removed. This will prevent possible siphoning and fuel system aeration.

If the engine fails to start after replacement of the fuel strainer and/or filter elements, the fuel system will require priming with tool J 5956 (or equivalent). Authorized Detroit Diesel service outlets are properly equipped to perform this service.

NOTICE:

Under no circumstances should the starting motor and fuel pump be used to prime the fuel filter and strainer. Prolonged use of the starting motor and fuel pump to prime the fuel system can result in damage to the starter, fuel pump, and injectors and cause erratic running of the engine due to the amount of air in the lines and filters.

F. Engine Out of Fuel—How to Restart

When an engine has run out of fuel, there is a definite procedure to follow when restarting it.

1. Fill the fuel tank with the recommended grade of fuel. If only partial filling is possible, add a minimum of 10 gallons (38 liters) of fuel to the tank.
2. Remove the fuel strainer/water separator from its cover, fill it with fuel, and reinstall it.
3. Remove the fuel filter from its cover, fill it with fuel, and reinstall it.
4. Start the engine, and check fuel filter and strainer for leaks.

If the engine fails to start after replacement of the fuel strainer and/or filter, the fuel system will require priming with tool J 5956 (or equivalent). Authorized Detroit Diesel service outlets are properly equipped to perform this service.

NOTICE:

Under no circumstances should the starting motor and fuel pump be used to prime the fuel filter and strainer. Prolonged use of the starting motor and fuel pump to prime the fuel system can result in damage to the starter, fuel pump, and injectors and cause erratic running of the engine due to the amount of air in the lines and filters.

G. How to Select Coolant Antifreeze

Use genuine Detroit Diesel Power Cool or an equivalent fully formulated, inhibited ethylene glycol (IEG)-base coolant (low silicate formulation) that meets or exceeds the standard of either the GM 6038-M formulation (GM 1899-M performance), or ASTM D 4985 requirements.

A 50% **Power Cool** antifreeze/water solution is normally used as a factory fill. Concentrations over 67% are not recommended because of poor heat transfer capability, adverse freeze protection and possible silicate dropout. Concentrations below 33% offer little freeze, boilover or corrosion protection.

If Detroit Diesel Power Cool or equivalent precharged inhibited ethylene glycol (IEG) is not used, Detroit Diesel Maintenance Product supplemental inhibitors must be added to the coolant at initial fill. Inhibitor levels in all coolants used must be maintained at proper concentration thereafter. Refer to “Proper SCA Dosage for Initial Fill and Maintenance Requirements” chart in this section. Refer to “Inhibitor Test Procedures” (page 58) for required inhibitor levels.

Antifreeze solution should be used year-round to provide freeze and boil-over protection as well as a stable environment for seals and hoses.

In extremely hot environments, clean, soft, properly inhibited water may be used if Detroit Diesel Maintenance Product supplemental corrosion inhibitors are also added in the right concentration. If water is used, supplemental coolant additive levels should be increased from 3% to 6% by volume (refer to **Specifications**, pages 73-74).

Only non-chromate inhibitors should be used with coolant solutions.

Coolant must be tested for required inhibitor levels at the intervals shown under “Coolant Test Intervals” in this section. Adjust the concentration if not at the proper protection level.

Mix coolant/water solution at the proper concentration before adding to the cooling system. This should prevent over- or under-coolant concentration problems.

Methyl alcohol-based antifreeze is not recommended for use in Detroit Diesel engines because of its effect on the non-metallic components of the cooling system and its low boiling point.

Methoxy propanol-based antifreeze is also not recommended because it is not compatible with

Initial Fill SCA Dosage		
Coolant	Coolant Element	Liquid
Precharged IEG* & Water	NONE	NONE
IEG & Water	Select Element from Specifications Page	3% by Volume or 1 Pint per 4 Gallons
Water only	Select Element from Specifications Page	6% by Volume or 1 Quart per 4 Gallons
*Such as Detroit Diesel Power Cool® antifreeze, or equivalent.		
Maintenance SCA Dosage		
Coolant Element		Liquid
Select Element from Specifications Page		0.6% by Volume or 1 Pint per 20 Gallons

Proper SCA Dosage for Initial Fill and Maintenance Requirements

fluoroelastomer seals found in the cooling system.

Glycol-based coolants formulated for heating/ventilation/air conditioning (HVAC) are *not recommended*. These generally contain very high levels of phosphates, which can deposit on hot internal engine surfaces and reduce the heat transfer ability of the metal.

Coolant Drain Interval

A cooling system properly maintained and protected with supplemental inhibitors can be operated up to these intervals:

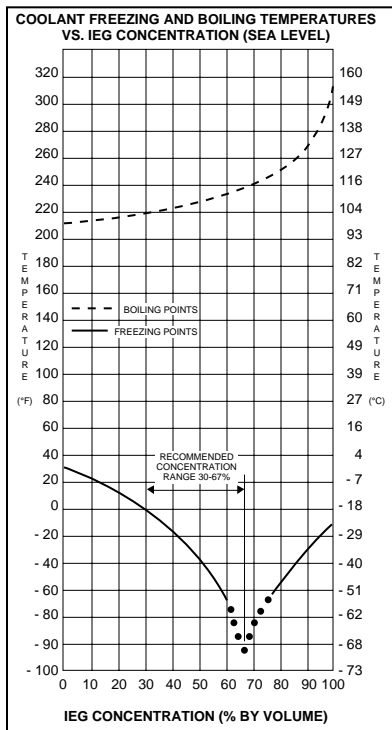

Coolant Freezing and Boiling Temperatures vs. Ethylene Glycol Antifreeze Concentration (Sea Level)

- On highway — two years or 200,000 miles (320,000 km)*
- Industrial, Gen Set — two years or 4,000 hours*
- Commercial Marine — Two years or 4,000 hours*
- Pleasure Craft Marine — One year or 1,000 hours*

*Whichever comes first
At these intervals the coolant must be drained and disposed of in an environmentally responsible manner, according to state and/or federal (EPA) recommendations, and the cooling system thoroughly cleaned.

Over a period of time normal maintenance dosages of supplemental coolant additives (SCA's) and ethylene glycol could result in the total dissolved solids being raised to a level that could cause the cooling system to lose some of its efficiency.

Inspect all components that make up the cooling system and make necessary repairs at this time. Refill the cooling system with a recommended ethylene glycol-base coolant and water solution at the required concentration. Add Detroit Diesel Maintenance Product cooling system inhibitors, if required. After filling, run engine until thermostat(s) open and top off coolant to recommended full level. Reinstall fill/pressure cap.

NOTICE:

Do not use sealer additives in the cooling system. The presence of the gummy and gelling material in stop-leak additives could cause plugging in the cooling passages, which will adversely affect the cooling system.

Detroit Diesel Maintenance Product Inhibitors System

Detroit Diesel Maintenance Product supplemental coolant inhibitors are a combination of chemical compounds which provide corrosion protection, cavitation suppression and pH control, and prevent scale. These systems are available in various forms, such as coolant elements, liquid packages, and as integral parts of antifreeze.

Detroit Diesel Maintenance Product supplemental coolant inhibitors are water-soluble chemical compounds which protect the metallic surfaces of the cooling system against corrosive attack. Some of the more common corrosion inhibitors used in the Maintenance Product line are borates, nitrites, and silicates.

- pH control chemicals are used to maintain an acid-free solution.
- Water-softening chemicals deter formation of mineral deposits.
- Cavitation suppression chemicals minimize the formation of vapor pockets, preventing erosion of cooling system surfaces.

It is imperative that Detroit Diesel Maintenance Product supplemental inhibitor be added to all Detroit Diesel engines.

Coolant Test Intervals

Service Application	Inhibitor Test Interval
On Highway Trucks and Motor Coaches	15,000 Miles (24,000 Kilometers)
City Transit Coaches, Pick-up and Delivery, Short Trip, and Emergency Vehicles	6,000 Miles (9,600 Kilometers) or three months, whichever comes first
Industrial, Marine, Generator Set, and all other Applications	200 Hours or yearly, whichever comes first

Refer to "Inhibitor Test Procedures" for required inhibitor levels.

Detroit Diesel Maintenance Product cooling system products are nitrite/borate-based formulations.

These products can be used with either water or water-and-coolant solutions and provide corrosion protection, pH control, and water softening. They offer the additional advantage of a simple on-site test to determine protection level.

Refer to **Specifications** (pages 73-74) for required coolant filter/inhibitor precharge and maintenance elements.

All inhibitors become depleted through normal operation, and additional inhibitor must be added to the coolant as required to maintain original strength levels.

NOTICE:

Overinhibiting with supplemental coolant additives or coolant concentrate can cause additive dropout. Always follow the coolant manufacturer's recommendations on usage and handling.

Soluble oils and chromate inhibitors are not recommended for use in Detroit Diesel engine cooling systems.

Inhibitor Test Procedures

Engine coolant must be tested for required inhibitor levels at the intervals shown on the "Coolant Test Intervals" chart. Test kits and test strips are commercially available to check engine coolant for nitrite concentration. Inhibitor levels must be maintained within the ranges shown on the following chart:

Detroit Diesel Maintenance Products System		
	Min. PPM	Max. PPM
Boron (B)	1000	1500
Nitrite (NO ₂)	800	2400
Nitrates (NO ₃)	1000	2000
Silicon (Si)	50	250
Phosphorous (P)	0	500
pH	8.5	10.5

Selected Products Supplemental Coolant Additive Values with GM6038-M or ASTM D 4985 (50/50 Glycol/Water Mixture)

Coolant test strips that measure glycol and nitrite concentration are available from authorized Detroit Diesel service outlets under part number 23515917. A factory coolant analysis program is also available under part number 23508774.

Silicate/Phosphate Dropout

Excessive amounts of chemicals in the engine coolant can cause additive dropout, which creates a gel-type or crystalline deposit that reduces heat transfer and coolant flow.

The gel takes the color of the coolant in the wet state, but appears as a white powdery deposit when dry. Although silica gel is non-abrasive, it can pick up solid particles in the coolant and become gritty, causing excessive wear of water pump seals and other cooling system components. The wet gel can be removed by using a non-acid (alkali) type heavy-duty cleaner such as Nalprep® 2001 (sodium nitrite/sodium tetraborate), while the dried silicate requires engine disassembly and caustic solution or mechanical cleaning of individual components.

Phosphate can drop out of solution and crystallize on heat transfer surfaces and water pump seal faces. Phosphate may be removed by flushing the system with water to redissolve crystals.

The total amount of chemicals in the coolant can be controlled to desirable levels by using the referenced antifreeze at the needed freeze protection concentration, adding Detroit Diesel Maintenance Product inhibitors and water that meets Detroit Diesel requirements.

NOTICE:
Failure to use and maintain coolant and coolant inhibitor mixture at sufficient concentration levels can result in damage to the cooling system and its related components. Conversely, overconcentration of coolant and/or inhibitor can result in poor heat transfer, leading to engine overheat, additive dropout, or both. Always maintain concentrations at recommended levels.

For more detailed coolant recommendations, refer to "Coolant Selections for Engine Cooling Systems," form 7SE298, available from authorized Detroit Diesel service outlets.

H. How to Drain and Flush the Cooling System

 CAUTION:
Do not remove the pressure control cap from the radiator or heat exchanger tank or attempt to drain the coolant until the engine has cooled. Once the engine has cooled, use extreme care when removing the cap. The sudden release of pressure from a heated cooling system can result in a loss of coolant and possible personal injury (scalding) from the hot liquid.

NOTICE:
An immersion-type engine block heater may be installed to improve cold weather starting. Always disconnect the electrical connections to the block heater <i>before</i> draining the coolant. Failure to disconnect electrical connections before draining coolant may result in damage to the block heater element if the heater is switched on without coolant in the system.

1. With the engine cool, drain the previous solution from the engine and radiator or heat exchanger tank. Dispose of the solution in an environmentally responsible manner according to state and/or federal (EPA) recommendations.
2. Refill the cooling system with clean, soft water and a good

radiator cleaning compound. If the engine is warm, fill slowly to prevent the rapid cooling and distortion of the metal castings.

3. Start the engine and operate it for fifteen minutes to circulate the solution thoroughly.
4. Stop the engine and allow it to cool.
5. With the engine cool, drain the cooling system completely.
6. Refill the cooling system with clean, soft water and operate it for fifteen minutes.
7. Stop the engine and allow it to cool.
8. With the engine cool, drain the cleaner residue from the cooling system.
9. Refill the system with the proper mix of antifreeze and clean, soft water.
10. Entrapped air must be purged after filling the cooling system. To do this, allow the engine to warm-up without the pressure cap installed. With the transmission or marine gear in neutral, increase engine speed above 1000 RPM and add coolant as required. If a water-jacketed turbocharger is installed, vent the petcock on the water return line at the turbocharger until a steady stream of coolant (no air) is seen. Then close the petcock.
Install the pressure cap after the coolant level has stabilized at the bottom of the radiator or heat exchanger tank filler neck. Fill the coolant recovery bottle (if equipped) to the "Full Cold" level, or no more than one-quarter of its volume.

NOTICE:

If all of the coolant is drawn out of the recovery bottle when the engine cools, remove the pressure control cap from the radiator or heat exchanger and check to make sure the coolant level is at or near the bottom of the filler neck. Add coolant as required to bring it to this level. Replace the pressure control cap and fill the recovery bottle to the "Full Cold" mark, or no more than one-quarter full. Do not overfill the recovery bottle since this can result in spillage as the coolant heats and expands during engine operation. Failure to properly fill the cooling system and purge it of air can result in engine overheating and serious engine damage.

NOTICE:

If the engine overheats and the coolant level is satisfactory, the cooling system may require cleaning with a descaling solvent and backflushing. Authorized Detroit Diesel service outlets are properly equipped to perform these services.

In addition to the cleaning procedure, other components of the cooling system should be checked periodically to keep the engine operating at peak efficiency.

I. When to Service the Dry Type Air Cleaner

Replace dry type air cleaner elements when the *maximum allowable air cleaner restriction* (20 inches of water or 5.0 kPa) has been reached, or annually, whichever comes first. Some air cleaners are equipped with a restriction indicator which aids in determining the service interval.

Cleaning and/or reusing dry paper type air cleaner elements is not recommended unless the cleaning method used removes clogging without damage to the element. Inspection and cleaning of elements must be done in accordance with the air cleaner manufacturers' recommendations, if any.

BASIC TROUBLESHOOTING

HARD STARTING

Probable Causes:

- Low battery voltage
- Loose cranking motor connections
- Faulty cranking motor
- Faulty cranking motor switch
- Internal seizure
- Improper lube oil
- Circuit breaker/electronic control malfunction
- Fuse blown or missing

Insufficient Fuel Supply

- Air in fuel
- Out of fuel
- Loose fuel connections
- Cracked fuel lines
- Obstructed fuel filters/lines
- Faulty fuel pump
- Faulty injector operation
- Restricted fuel-fitting missing
- DDEC malfunction

Low Compression

- Worn intake and exhaust valves
- Worn piston rings/liners
- Leaking cylinder head gasket
- Improper intake and exhaust valve adjustments

Engine Will Not Rotate		
Low Cranking Speed		Engine Cranks But Will Not Start
X	X	
X		
X	X	
X	X	X
X		
	X	
		X
		X
		X
		X
		X
		X
		X
		X
		X
		X
		X
		X
		X
		X
		X
		X

OBJECTIONABLE EXHAUST

Probable Causes:

Damaged or dirty air cleaner
 Improper grade of fuel
 Excessive exhaust back pressure
 Misfiring cylinders
 Lubricating oil not burned in cylinder (being burned in exhaust manifold or turbocharger)
 Faulty injector setting
 Faulty oil control rings
 Excessive installation angle
 Excessive oil in crankcase
 High ambient air temperature
 Thin air (high altitude)
 Cetane rating of fuel too low
 Air in the fuel system

	Black or Gray Smoke		
	Blue Smoke		White Smoke
Damaged or dirty air cleaner	X		
Improper grade of fuel	X		
Excessive exhaust back pressure	X		
Misfiring cylinders			X
Lubricating oil not burned in cylinder (being burned in exhaust manifold or turbocharger)		X	
Faulty injector setting	X		
Faulty oil control rings		X	
Excessive installation angle		X	
Excessive oil in crankcase		X	
High ambient air temperature	X		
Thin air (high altitude)	X		
Cetane rating of fuel too low			X
Air in the fuel system			X

ABNORMAL ENGINE OPERATION

Probable Causes:

Misfiring cylinder
 Insufficient fuel
 High return fuel temperature
 Low compression
 DDEC malfunction
 High air inlet restriction/exhaust back pressure
 Engine application
 High air inlet temperature
 High altitude operation
 Incorrect engine gear train timing
 Low coolant temperature
 Oil picked up by inlet airstream
 Faulty injector operation
 Incorrect injector height setting

	Rough Running or Frequent Stalling		
	Low Power		Detonation
Misfiring cylinder	X	X	
Insufficient fuel	X	X	
High return fuel temperature	X	X	
Low compression	X	X	
DDEC malfunction	X	X	
High air inlet restriction/exhaust back pressure		X	
Engine application		X	
High air inlet temperature		X	
High altitude operation		X	
Incorrect engine gear train timing		X	
Low coolant temperature			X
Oil picked up by inlet airstream			X
Faulty injector operation			X
Incorrect injector height setting		X	X

ABNORMAL OPERATING CONDITIONS

Probable Causes:

Loose connections
 Cracked lines
 Damaged gaskets or seal rings
 * Lube oil loss at breather tube
 * Lube oil loss at dipstick tube

[*Indicates high crankcase pressure]

Leaking oil cooler
 Leaking valve stem seals
 Worn/broken oil control rings
 Scored liner and/or piston
 Excessive engine installation angle
 Crankcase overfilled
 Oil in air tanks (air compressor malfunction)
 Plugged crankcase breather
 Oil level low
 Improper engine oil viscosity (fuel in the oil)
 Faulty oil pressure regulator valve
 Worn crankshaft bearings
 Worn camshaft or connecting rod bearings
 Missing cup plugs in rocker arm shafts
 Faulty oil pressure relief valve
 Air leaks in oil pump (suction side)
 Worn or damaged oil pump
 Faulty oil pressure gage
 Faulty electrical components (for gage)
 Plugged oil orifice
 Obstructed oil line

	High Lubricating Oil Consumption	
		Low Oil Pressure
Loose connections	X	
Cracked lines	X	
Damaged gaskets or seal rings	X	
* Lube oil loss at breather tube	X	
* Lube oil loss at dipstick tube	X	
Leaking oil cooler	X	
Leaking valve stem seals	X	
Worn/broken oil control rings	X	
Scored liner and/or piston	X	
Excessive engine installation angle	X	
Crankcase overfilled	X	
Oil in air tanks (air compressor malfunction)	X	
Plugged crankcase breather	X	
Oil level low		X
Improper engine oil viscosity (fuel in the oil)		X
Faulty oil pressure regulator valve		X
Worn crankshaft bearings		X
Worn camshaft or connecting rod bearings		X
Missing cup plugs in rocker arm shafts		X
Faulty oil pressure relief valve		X
Air leaks in oil pump (suction side)		X
Worn or damaged oil pump		X
Faulty oil pressure gage		X
Faulty electrical components (for gage)		X
Plugged oil orifice		X
Obstructed oil line		X

ABNORMAL COOLANT TEMPERATURES

Probable Causes:

Restricted cooling system passages
 Restricted radiator core passages
 Slipping fan drive belts
 Faulty temperature-controlled fan
 Obstruction in front of radiator or intercooler
 Low coolant level
 Damaged hoses
 Faulty thermostats
 Faulty water pump
 Faulty radiator pressure cap
 Air in coolant
 Thermostats not fully closed
 Leakage around thermostat seals
 Faulty temperature-controlled fan

Above Normal	
Below Normal	
Restricted cooling system passages	X
Restricted radiator core passages	X
Slipping fan drive belts	X
Faulty temperature-controlled fan	X
Obstruction in front of radiator or intercooler	X
Low coolant level	X
Damaged hoses	X
Faulty thermostats	X
Faulty water pump	X
Faulty radiator pressure cap	X
Air in coolant	X
Thermostats not fully closed	X
Leakage around thermostat seals	X
Faulty temperature-controlled fan	X

ENGINE STORAGE

Preparing Engine for Storage

When an engine is to be stored or removed from operation for a period of time, special precautions should be taken to protect the interior and exterior of the engine, transmission and other parts from rust accumulation and corrosion. The parts requiring attention and the recommended preparations are given below.

It will be necessary to remove all rust or corrosion completely from any exposed part before applying rust preventive compound. Therefore, it is recommended that the engine be processed for storage as soon as possible after removal from operation.

The engine should be stored in a building that is dry and can be heated during the winter months. Moisture absorbing chemicals are available commercially for use when excessive dampness prevails in the storage area.

Temporary Storage (30 Days or Less)

To protect an engine for a temporary period of time, proceed as follows:

1. Drain the engine crankcase.
2. Fill the crankcase to the proper level with the recommended viscosity and grade of oil.
3. Fill the fuel tank with the recommended grade of fuel oil. Operate the engine for two minutes at 1200 rpm and no load. **Do not drain the fuel system or the crankcase after this run.**
4. Check the air cleaner and service it, if necessary.

5. If freezing weather is expected during the storage period, check the antifreeze/coolant for required freeze and inhibitor protection. Add an ethylene glycol base antifreeze solution to the cooling system to provide required freeze and inhibitor protection.

NOTE: If an antifreeze solution is not required during storage, flush the cooling system with a good rust inhibitor to prevent rusting of the outside diameter of the cylinder liners.

6. Clean the exterior of the engine (except electrical components) with fuel oil and dry with compressed air.

	CAUTION:
To prevent possible personal injury when using compressed air, wear adequate eye protection and do not exceed 40 psi (276 kPa) air pressure.	

7. Seal all engine openings. The material used must be waterproof, vapor-proof and possess sufficient physical strength to resist puncture and damage from the expansion of entrapped air.

An engine prepared in this manner can be returned to service in a short time by removing the seals at the engine openings and by checking the engine coolant, fuel oil, lubricating oil and transmission oil levels.

Extended Storage (More than 30 Days)

To prepare an engine for extended storage (more than 30 days), follow this procedure:

1. Drain the cooling system and flush with clean, soft water. Refill with clean, soft water and add a rust inhibitor to the cooling system.
2. Circulate the coolant by operating the engine until normal operating temperature is reached.
3. Stop the engine.
4. Drain the engine crankcase, then reinstall and tighten the 3/4"-14 square, magnetic oil drain plug to 45-50 N•m (33-37 lb-ft) torque. Install new lubricating oil filters.
5. Fill the crankcase to the proper level with a 30-weight preservative lubricating oil MIL-L-21260C, Grade 2.
6. Drain the fuel tank. Refill with enough clean No. 1 diesel fuel or pure kerosene to permit the engine to operate for about ten minutes. If draining the fuel tank is not convenient, use a separate, portable supply of recommended fuel.

NOTE: If engines in vehicles are stored where condensation of water in the fuel tank may be a problem, add pure, waterless isopropyl alcohol (isopropanol) to the fuel at a ratio of one pint to 125 gallons of fuel, or 0.10% by volume. Where biological contamination of fuel may be a problem, add a biocide such as Biobor JF (or equivalent) to the fuel. When using a biocide, follow the manufacturer's concentration recommendations, and observe all cautions and warnings.

7. Drain the fuel system and remove the fuel filters. Dispose of used filters in an environmentally responsible manner, according to state and/or federal (EPA) recommendations. Fill new filters with No. 1 diesel fuel or pure kerosene, and reinstall on the engine.
8. Operate the engine for five minutes to circulate the clean fuel oil throughout the engine. Be sure the engine fuel system is full. Disconnect the fuel return line and the inlet line at the primary filter and securely plug both to retain the fuel in the engine.
9. Service the air cleaner.
10. **Transmission**—Follow the manufacturer's recommendations for prolonged storage.
11. **Power Take-Off**— (If equipped)— Follow the manufacturer's recommendations for prolonged storage.

12. **Turbocharger**—Since turbocharger bearings are pressure lubricated through the external oil line leading from the oil filter adapter while the engine is operating, no further attention is required. However, the turbocharger air inlet and turbine outlet connections should be sealed off with moisture-resistant tape.

NOTICE:

Failure to properly seal off turbocharger air inlet and exhaust outlet openings before engine storage may permit air drafts to circulate through the turbocharger and rotate the turbine/compressor shaft without an adequate flow of lubricating oil to the center housing bearings. This can result in severe bearing damage.

13. Apply a non-friction rust preventive compound to all exposed engine parts. If convenient, apply the rust preventive compound to the engine flywheel. If not, disengage the clutch mechanism to prevent the clutch disc from sticking to the flywheel.
- NOTE:** Do not apply oil, grease or any wax base compound to the flywheel. The cast iron will absorb these substances, which can "sweat" out during operation and cause the clutch to slip.
14. Drain the engine cooling system.
 15. Drain the preservative oil from the engine crankcase. Reinstall and tighten the drain plug.

16. Remove and clean the battery and battery cables with a baking soda-water solution and rinse with fresh water. Do not allow the soda solution to enter the battery. Add distilled water to the electrolyte (if necessary) and fully charge the battery. Store the battery in a cool (never below 0°C or 32°F) dry place. Keep the battery fully charged and check the level and specific gravity of the electrolyte regularly.
17. Insert heavy paper strips between the pulleys and drive belts to prevent sticking.
18. Seal all engine openings including the exhaust outlet, with moisture-resistant tape. Use cardboard, plywood or metal covers where practical.
19. Clean and dry the exterior painted surfaces of the engine and spray with a suitable liquid automobile body wax, a synthetic resin varnish, or a rust preventive compound.
20. Protect the engine with a good weather-resistant tarpaulin and store it under cover, preferably in a dry building which can be heated during the winter months.

Outdoor storage of engines is not recommended. If units must be kept out-of-doors, follow the preparation and storage instructions already given. Protect units with quality, weather-resistant tarpaulins (or other suitable covers) arranged to provide for air circulation.

NOTICE:

Do not use plastic sheeting for outdoor storage. Plastic is fine for indoor storage. When used outdoors, however, enough moisture can condense on the inside of the plastic to rust ferrous metal surfaces and pit aluminum surfaces. If a unit is stored outside for any extended period of time, severe corrosion damage can result.

The stored engine should be inspected periodically. If there are any indications of rust or corrosion, corrective steps must be taken to prevent damage to the engine parts. Perform a complete inspection at the end of one year and apply additional treatment as required.

Procedure for Restoring to Service an Engine that Has Been in Extended Storage

1. Remove the covers and tape from all of the openings of the engine, fuel tank and electrical equipment. Do not overlook the exhaust outlet.
2. Remove the plugs from the inlet and outlet fuel lines and reconnect the lines to their proper positions.
3. Wash the exterior of the engine with fuel oil to remove the rust preventive. **Do not wash electrical components.**
4. Remove the rust preventive from the flywheel.
5. Remove the paper strips from between the pulleys and drive belts.
6. Fill the crankcase to the proper level with the required grade of lubricating oil. Use a pressure lubricator to insure all bearings and rocker shafts are lubricated.
7. Fill the fuel tank with the required fuel.
8. Close all drain cocks and fill the engine cooling system with clean, soft water and required inhibitors. If the engine is to be exposed to freezing temperatures, install genuine Detroit Diesel **Power Cool**® antifreeze or an equivalent ethylene glycol-base antifreeze solution in the required concentration.

9. Install and connect the battery. Make sure the average specific gravity of the battery is 1.260 or higher. Charge the battery if necessary.
10. Service the air cleaner, if required.
11. **Transmission**—Follow the manufacturer's recommendations covering the return of the transmission to service.
12. **Power Take-Off** (If equipped) — Follow the manufacturer's recommendations covering the return of the power take-off to service.
13. **Turbocharger**—Remove the covers from the turbocharger air inlet and turbine outlet connections. Reconnect piping as required. Prelube the turbocharger. Refer to the lubricating procedure outlined in "Preparations for Starting the Engine the First Time" (page 3).

14. After all preparations are completed, start the engine. The small amount of rust preventive compound which remains in the fuel system will cause smoky exhaust for a few minutes.

NOTE: Before subjecting the engine to a load or high speed, allow it to reach normal operating temperature. Then, monitor the DDEC Diagnostic Data Link (if equipped) for trouble codes.

SERVICE PUBLICATIONS

The service manual covering Detroit Diesel Series 92 engines is shown below. Also listed are reference works which may be of interest to the owner/operator.

To purchase a copy of any of these publications, contact an authorized

Detroit Diesel service outlet. Check the Yellow Pages under "Engines, Diesel" or refer to the Worldwide Distributor and authorized Dealer Directory (form 6SE280) for the distributor or service outlet nearest you.

Description	Form No.
Series 92 Engine Service Manual	6SE379
DDEC II Troubleshooting Guide	6SE489
DDEC III Troubleshooting Guide	6SE492
Marine DDEC Troubleshooting Guide	6SE490
Worldwide Distributor/Dealer Directory	6SE280
Engine Requirements— Lubricating Oil, Fuel, and Filters	7SE270
Coolant Selections for Engine Cooling Systems	7SE298

CUSTOMER ASSISTANCE

The satisfaction and goodwill of the owners of Detroit Diesel engines are of primary concern to Detroit Diesel Corporation and its distributor/dealer organizations.

As the owner of a Detroit Diesel product you have a complete network of over 2,000 Detroit Diesel service outlets in the U.S. and Canada, plus many outlets worldwide that are prepared to meet your parts and service needs:



EASTERN REGION
Long Branch, New Jersey
 187 Monmouth Park Highway
 West Long Branch, NJ 07764
 Phone: (908) 222-1888
 Fax: (908) 222-3411

SOUTHEASTERN REGION
Jacksonville, Florida
 5111 Bowden Road
 Jacksonville, FL 32216
 Phone: (904) 448-8833
 Fax: (904) 448-2444

CENTRAL REGION
Detroit, Michigan
 13400 Outer Drive, West
 Detroit, MI 48239-4001
 Phone: (313) 592-5990
 Fax: (313) 592-5158

SOUTHWESTERN REGION
Dallas, Texas
 2711 LBJ Freeway
 Suite 1036
 Dallas, TX 75234
 Phone: (214) 247-4313
 Fax: (214) 247-4316

WESTERN REGION
Downey, California
 10645 Studebaker Road
 Downey, CA 90241
 Phone: (310) 929-7016
 Fax: (310) 864-0502

CANADIAN REGION
London, Ontario
 Detroit Diesel of Canada Ltd.
 150 Dufferin Ave., Suite 701
 London, ON N6A 5N6
 Phone: (519) 661-0149
 Fax: (519) 661-0171

LATIN AMERICAN REGION
Miami, Florida
 2277 N.W. 14th Street
 Miami, FL 33125-0068
 Phone: (305) 637-1555
 Fax: (305) 637-1580

ASIAN REGION
Singapore
 7 Jurong Pier Rd.
 Singapore 2261
 Phone: (65) 265-4697
 Fax: (65) 265-9530

PACIFIC REGION
Australia
 13 Lynette Ave.
 Beaumaris, Victoria 3193
 Australia
 Phone: (61) 3-5895181
 Fax: (61) 3-5893424

**EUROPE, MIDDLE EAST,
 AFRICA (EMA) REGION**
The Netherlands
 Ridderpoort 9
 2980 GD Ridderkerk
 The Netherlands
 Phone: (31) 1804-10388
 Fax: (31) 1804-62062

MEXICO
**Detroit Diesel-Allison de
 Mexico, S.A.**
 Reforma 2977
 Colonia, Cuajimalpa
 Mexico, D.F. 05000, Mexico
 Phone: (525) 626-5301
 Fax: (525) 626-5314

- Service by trained personnel.
- Sales teams to help determine your specific power requirements.
- In many areas, emergency service 24 hours a day.
- A complete line of genuine Detroit Diesel maintenance products.
- Complete parts support including **reliabilt**® components.
- Product information and literature.

We recognize however, that despite the best intentions of everyone concerned, misunderstandings may occur. Normally, any situation that arises in connection with the sale, operation or service of your product will be handled by the authorized service outlet in your area (in the U.S. and Canada check the Yellow Pages for the Detroit Diesel service outlet nearest you).

To further assure your complete satisfaction, we have developed the following procedure to be followed in the event you have a problem that has not been handled satisfactorily.

Step One

Discuss your problem with a member of management from the authorized service outlet. Frequently, complaints are the result of a breakdown in communication and can quickly be resolved by a member of management. If you have already discussed the problem with the Sales or Service Manager, contact the General Manager. If your complaint originates with a dealer, explain the matter to a management member of the authorized Detroit Diesel distributorship with whom the dealer has his service agreement.

Step Two

When it appears that your problem cannot readily be resolved at the distributor level without additional assistance, contact the Detroit Diesel Corporate Regional Product Support or Operations Manager responsible for your local distributor. You will be assisted by a member of the Manager's staff, depending upon the nature of your problem.

Prior to this contact, have the following information available:

- **Engine Serial Number*** _____
- Name and location of authorized service outlet.
- Type and make of equipment.
- Engine delivery date and accumulated hours of operation.
- Nature of problem.
- Chronological summary of engine's history.

***Important:** Your engine serial number should be written on the line provided. It will identify your model and all service parts, plus provide warranty and extended coverage information.

Step Three

If you are still not satisfied, present the entire matter in writing or by phone to:

**Director,
Reliability and Service**
Detroit Diesel Corporation
13400 Outer Drive, West
Detroit, Michigan 48239-4001
Phone: (313) 592-7357

When contacting the regional or home office, please keep in mind that ultimately your problem will likely be resolved at the distributorship or dealership, utilizing their facilities, equipment, and personnel. Therefore, it is suggested that you follow the above steps in sequence when experiencing a problem.

SPECIFICATIONS

LUBRICATING OIL FILTERS			
Filter Type	Detroit Diesel Part No.	AC Part No.	Micron Rating @ 98% Single Pass Efficiency
Full Flow	25013192	PF-911L	12

FUEL FILTERS			
Filter Type	Detroit Diesel Part No.	AC Part No.	Micron Rating @ 98% Single Pass Efficiency
Spin-On			
Primary			
6V, 8V-92	25014274	TP915D	25
12V, 16V-92	25014341	TP958	25
Primary w/Separator	23512317	—	25
Secondary			
6V, 8V-92	25014342	TP916D	8
12V, 16V-92	25011026	TP959	8
ALL DDEC	25013535#	TP959L	5

#Required on DDEC engines.

COOLANT INHIBITOR ELEMENT SIZE REQUIREMENTS — INITIAL FILL DOSAGE FOR IEG* PLUS WATER COOLANT MIXTURES			
COOLING SYSTEM CAPACITY, GALLONS**	QTY.	DDC PART NUMBER	NALCOOL PART NUMBER
5-8	1	23508425	DDF-3000.8
9-12	1	23508426	DDF-3000.12
13-16	1	23507189	DDF-60.16
24-32	1	23508427	DDF-3000.32
47-52	1	23508428	DDF-3000.53

* IEG = Inhibited Ethylene Glycol.

** Engine, radiator or heat exchanger, and all cooling system piping.

**COOLANT INHIBITOR ELEMENT SIZE REQUIREMENTS —
INITIAL DOSAGE FOR WATER-ONLY SYSTEMS**

COOLING SYSTEM CAPACITY, GALLONS*	SCA ELEMENT QUANTITY	DETROIT DIESEL SCA ELEMENT PART NO.	NALCOOL ELEMENT PART NO.	ADDITIONAL SCA LIQUID REQUIRED
5	1	23508425	DDF-3000.8	None
7	1	23508426	DDF-3000.12	None
10	1	23507189	DDF-60.16	None
15	2	23508426	DDF-3000.12	None
20	1	23508427	DDF-3000.32	None
25	1	23508427	DDF-3000.32	None
	1	23507545	DDF-3000.4	
30	1	23508427	DDF-3000.32	None
	1	23508426	DDF-3000.12	
35	1	23508427	DDF-3000.32	None
	1	23507189	DDF-60.16	
40	2	23508427	DDF-3000.32	None
50	2	23508427	DDF-3000.32	None

**COOLANT INHIBITOR ELEMENT SIZE REQUIREMENTS — MAINTENANCE
DOSAGE FOR IEG*, PRECHARGED, AND WATER-ONLY COOLANT MIXTURES**

COOLING SYSTEM CAPACITY, GALLONS**	QTY.	DDC PART NUMBER	NALCOOL PART NUMBER
5-8	1	23507545	DDF-3000
9-12	1	23507545	DDF-3000
13-16	1	23507545	DDF-3000
24-32	1	23508425	DDF-3000.8
47-52	1	23508426	DDF-3000.12

* IEG = Inhibited Ethylene Glycol.

** Engine, radiator or heat exchanger, and all cooling system piping.

**ADDITIONAL COOLANT INHIBITOR
TREATMENT PRODUCTS**

Item	Size	Detroit Diesel Part No.
Power Cool -Antifreeze/Coolant	Gallon Jug (6 per carton)	23512138
	55 Gallon Drum	23512139
NALCOOL 2000* -Liquid	Pint (12 per case)	23507858
	Half Gallon (6 per case)	23507859
	5 Gallon	23507860
NALCOOL 3000* -Liquid	Pint (12 per case)	23507854
	Half Gallon (6 per case)	23507855
	5 Gallon	23507856
NALPREP 2001* -Liquid On-Line Cleaner	Half Gallon (6 per case)	23507862
	5 Gallon	23507863
Nalcool 2015* Twin Pac- Dry Chemical Cleaner/Conditioner	2 per case	23507867

*NALCOOL and NALPREP are licensed trademarks of the Penray Companies.

NOTES

NOTES

NOTES